

FORCES

PART 2

AQA GCSE Physics

STUDENT EDITION

Contents

Lesson	Topic	Page
1	Introduction to Forces	3
2	Mass, Weight and Gravity	10
3	Resultant Force	13
4	Work Done and Energy Transfer	17
5	Newton's Laws	21
6	Required Practical 7: Newton's Second Law	27
7	Terminal Velocity	32
8	Momentum	36
9	Conservation of Momentum	40
10	Stopping Distance	44
11	Hooke's Law	49
12	Hooke's Law Practical	55

Name: _____

Teacher: _____

Key Terms	
Term	Definition
Scalar	A quantity with magnitude (size) only — no direction.
Vector	A quantity with both magnitude and an associated direction.
Vector representation	Vectors are shown by an arrow — the length shows size, the direction shows direction.
Scalar examples	Distance, speed, energy, temperature.
Vector examples	Displacement, velocity, acceleration, forces.
Force	A push or pull on an object when it interacts with another object.
Contact forces	A force acting between objects that are physically touching.
Contact force examples	Friction, air resistance, tension and normal contact force.
Non-contact forces	A force acting between objects that are physically separate.
Non-contact force examples	Gravitational force, electrostatic force and magnetic force.
Resultant force	Equal to the sum of all the forces acting on an object.
Equilibrium	When the forces acting on an object cancel each other out.
Scale diagram	Vectors are drawn as arrows head-to-tail to show the final, resultant force.
Free body diagram	A diagram of the forces acting on an object.
Forcemeter	A spring and scale to measure the size of a given force (Newtonmeter).
Force components	When one force can be split into two vector parts.
Mass	The total matter contained in an object, measured in kilograms.
Weight	The force acting on an object due to gravity.
Gravitational field strength	Size of gravitational force in Newtons for each kg of mass at a given location.
Centre of mass	A single point at which the weight could be considered to act upon.
Forces balanced	When the forces on an object cancel out (resultant force = 0).
Forces not balanced	When there is a net force (resultant) acting on an object.
Newton's 1st Law	Objects stay at rest or at constant speed unless a resultant force acts upon them.
Newton's 2nd Law	If there is a resultant force, an object accelerates — acceleration is proportional to force and inversely proportional to mass.
Newton's 3rd Law	For each force on an object, the object reacts with the same force in return.
Distance	The length of space between two points.
Displacement	Distance in a given direction.
Speed	How much distance is covered in a given time.
Velocity	Speed in a given direction.
Acceleration	How much the speed changes in a given time.
Calculating speed	The gradient of a line on a distance-time graph.
Calculating acceleration	The gradient of a line on a speed-time graph.
Calculating distance covered	The area under a curve on a distance-time graph.
Stopping distance	The distance a vehicle travels between when a hazard is seen and when the vehicle has stopped.
Thinking distance	The distance travelled between when a hazard is seen and the brake is pressed.
Braking distance	The distance travelled between when the brake is pressed and the vehicle has stopped.
Momentum	The strength of motion of an object (mass \times velocity).
Increasing time of impact	Decreases the force acting on the object during a collision.
Seat belt	Slows down the time of deceleration of a person during a collision.
Airbag	Spreads the time of deceleration of a person during a collision.

LESSON 1

Introduction to Forces**Do Now**

1. What is the SI unit of force?
2. Name one instrument used to measure a force directly.
3. State the difference between a scalar quantity and a vector quantity.
4. Give two examples of vector quantities and two examples of scalar quantities.

Part 1 of 3 | Forces, Scalars and Vectors

A force is a push or pull. Forces have units of Newtons (N). We measure force using a Newton meter.	1
Scalar quantities have size ("magnitude") only and no direction. Example: mass.	2
Scalar quantities can be added normally. Example: $36 \text{ kg} + 14 \text{ kg} = 50 \text{ kg}$.	3
Vector quantities have both size (magnitude) and direction.	4
Examples of scalars: mass, distance, speed, energy, time, power.	5
Examples of vectors: force, velocity, acceleration, displacement, weight, momentum.	6

Questions

1. What is a force? (1 mark)
2. What is the unit of force? (1 mark)
3. What instrument do we use to measure forces? (1 mark)
4. What is the definition of a scalar quantity? Give three examples of scalar quantities. (2 marks)
5. What is the definition of a vector quantity? Give three examples of vector quantities. (2 marks)

Part 2 of 3 | Scale Diagrams

In a scale diagram (1 cm = 1 N) each force is drawn as an arrow of the appropriate length and direction.	1
Place the arrows head-to-tail. The resultant is the arrow from the start of the first to the end of the last.	2
Measure the resultant arrow length (then scale back) to find the magnitude of the resultant force.	3

How to find resultant from scale drawing

1. Find the scale (1 cm = ?)
2. Measure resultant
3. Multiply by scale

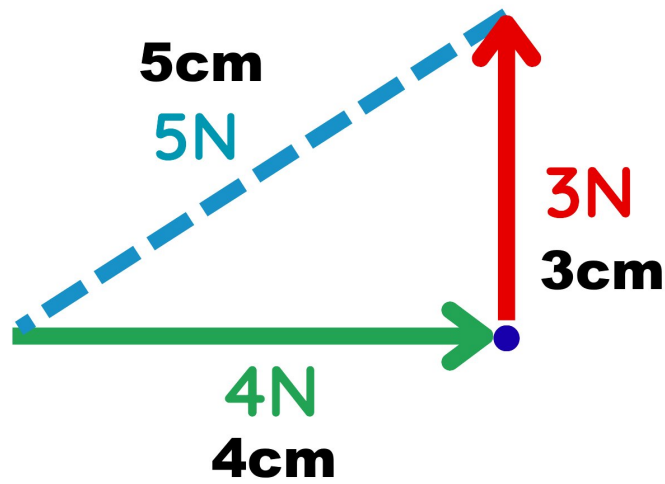

Fig 1.1 — Finding resultants from scale drawings (scale: 1 cm = 1 N)

Questions

6. Find the resultant for each.

(18 marks)

a

Scale = _____
 Resultant length = _____
 Resultant force = _____

b

Scale = _____
 Resultant length = _____
 Resultant force = _____

c

Scale = _____
 Resultant length = _____
 Resultant force = _____

d

Scale = _____
 Resultant length = _____
 Resultant force = _____

e

Scale = _____
 Resultant length = _____
 Resultant force = _____

f

Scale = _____
 Resultant length = _____
 Resultant force = _____

g

Scale = _____
 Resultant length = _____
 Resultant force = _____

h

Scale = _____
 Resultant length = _____
 Resultant force = _____

i

Scale = _____
 Resultant length = _____
 Resultant force = _____

j

Scale = _____
 Resultant length = _____
 Resultant force = _____

k

Scale = _____
 Resultant length = _____
 Resultant force = _____

l

Scale = _____
 Resultant length = _____
 Resultant force = _____

m

Scale = _____
 Resultant length = _____
 Resultant force = _____

n

Scale = _____
 Resultant length = _____
 Resultant force = _____

o

Scale = _____
 Resultant length = _____
 Resultant force = _____

p

Scale = _____
 Resultant length = _____
 Resultant force = _____

q

Scale = _____
 Resultant length = _____
 Resultant force = _____

r

Scale = _____
 Resultant length = _____
 Resultant force = _____

Drawing scale resultants

1. Choose a scale (1 cm = ?)
2. Draw the 2 vectors tip to tail
3. Measure the resultant
4. Multiply by scale

7. For each of the following draw a scale diagram and find the resultant.

(20 marks)

Question	Horizontal Force (N)	Vertical Force (N)	Scale (1 cm = ? N)	Horiz. cm	Vert. cm
7	560	740	100	5.6	7.4
8	3	4			
9	90	40			
10	15	20			
11	600	800			
12	5	5			
13	30	40			
14	500	500			
15	8	6			
16	360	480			
17	60	80			
18	7	4			
19	250	300			
20	24	32			
21	750	600			
22	12	16			
23	420	560			
24	50	50			
25	300	400			
26	45	60			

27. A woman walks 200 m east and then 100 m south.

- (a) Find the total distance travelled.
- (b) Find the resultant displacement (magnitude and direction).

(3 marks)

28. Dr Edmunds' cat Lola runs after a squirrel 40 m north and 30 m west.

- (a) What is the distance that Lola has run?
- (b) What is Lola's resultant displacement?

(3 marks)

Part 3 of 3 | Pythagoras' Theorem and Resultant Vectors

If one vector is at right angles to another, we can use Pythagoras' theorem to find the resultant vector (the combined effect of more than one vector).

Pythagoras' theorem: $a^2 + b^2 = c^2$

We can also use scale diagrams to find a resultant vector.

In a scale diagram, draw each vector as an arrow to scale. Join them head-to-tail. The resultant is the arrow from start to finish.

The resultant vector is found by placing vectors head-to-tail and drawing an arrow from the tail of the first to the head of the last.

The direction of the resultant can be measured with a protractor from the scale diagram.

$$a^2 + b^2 = c^2$$

$$c = \sqrt{a^2 + b^2}$$

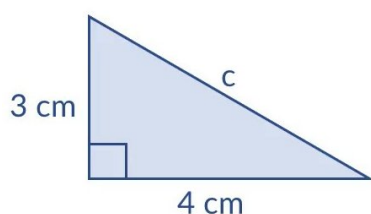

$$c = \sqrt{3^2 + 4^2}$$

$$c = \sqrt{9 + 16}$$

$$c = \sqrt{25}$$

$$c = 5$$

Worked example — finding the resultant force c when $a = 3\text{ N}$ and $b = 4\text{ N}$

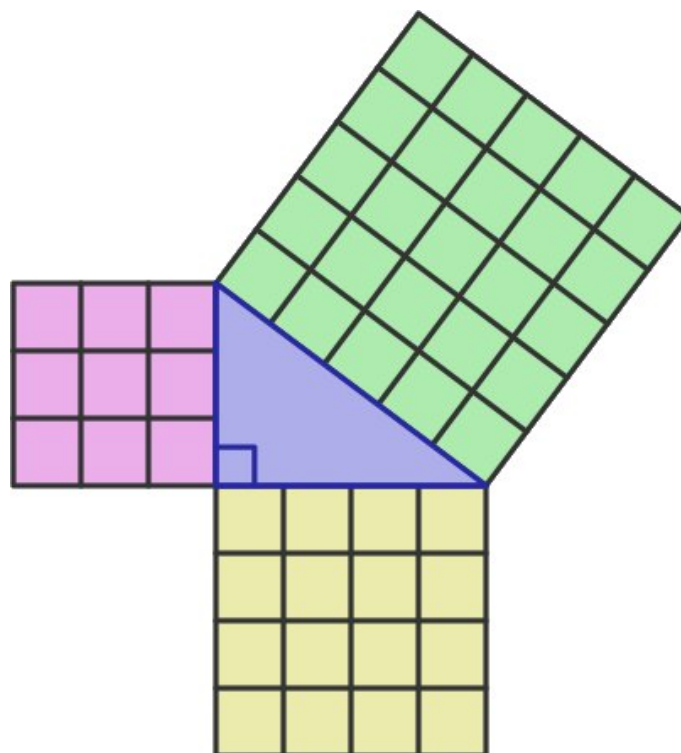

Fig 1.2 — Pythagoras' theorem: squares on each side show $a^2 + b^2 = c^2$ ($a=3$, $b=4$, $c=5$)

Questions

34. Use Pythagoras' theorem to find the resultant force c for each triangle below.

(10 marks)

a.

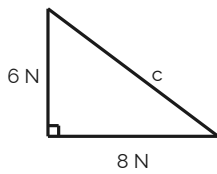

b.

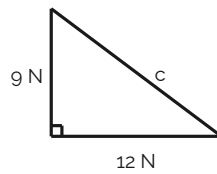

c.

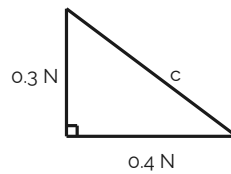

d.

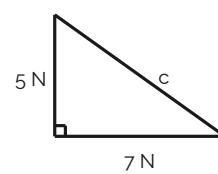

e.

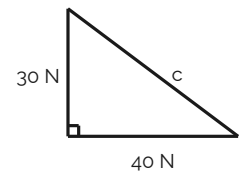

f.

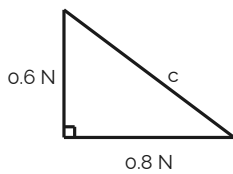

g.

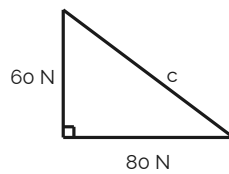

h.

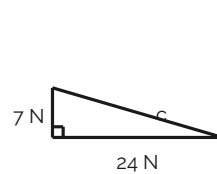

i.

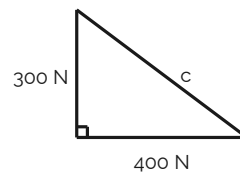

j.

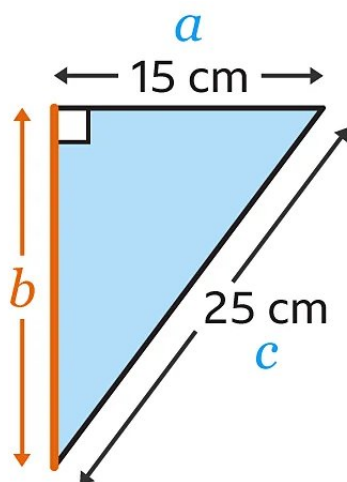
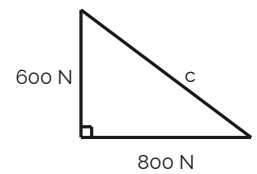

$$\begin{aligned}
 a^2 + b^2 &= c^2 \\
 15^2 + b^2 &= 25^2 \\
 225 + b^2 &= 625 \\
 -225 & \quad -225 \\
 b^2 &= 400 \\
 b &= \sqrt{400} \\
 b &= 20
 \end{aligned}$$

Worked example — finding missing side b when $c = 25$ N and $a = 15$ N

35. Use Pythagoras' theorem to find the missing vector for each triangle below.

(10 marks)

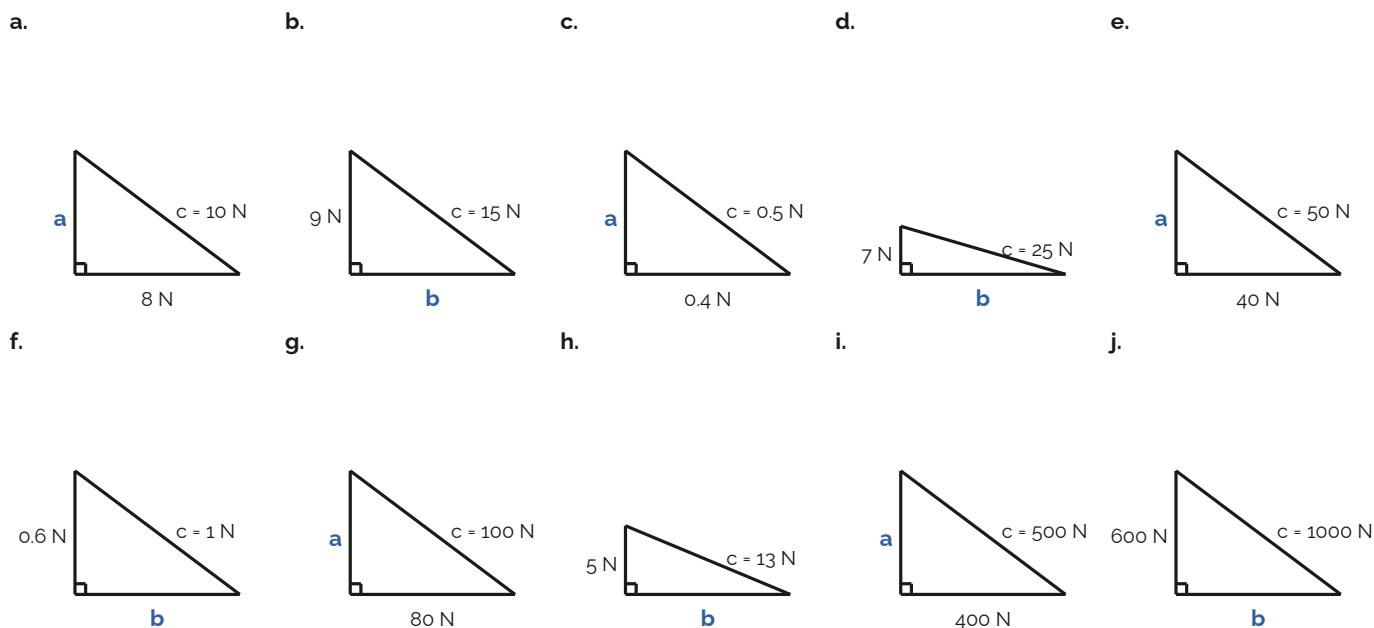

29. An aeroplane travels with a speed of 100 m/s north and a speed of 20 m/s east. What is the plane's overall velocity (magnitude and direction)?

(2 marks)

30. A car travels 9 km east and then 12 km north.

- (a) Find the total distance travelled.
- (b) Find the resultant displacement (magnitude and direction).

(3 marks)

31. A swimmer crosses a river that is 40 m wide, swimming directly across. The current carries them 30 m downstream before they reach the other side.

- (a) What is the total distance swum?
- (b) What is the resultant displacement (magnitude and direction)?

(3 marks)

32. A bird flies at 15 m/s heading south but is blown 8 m/s to the east by the wind. What is the bird's resultant velocity (magnitude and direction)?

(2 marks)

EXAM QUESTION — Q1: Scalars, Vectors and Resultant Forces (6 marks)

Mark allocations shown as (n) following AQA convention.

(a) State the difference between a scalar quantity and a vector quantity, giving one example of each.

(4)

(b) Draw scale diagrams (1 cm = 1 N) to work out the resultant force when: (i) 4 N east and 4 N north act on an object. (ii) 6 N east and 4 N north act on an object.

(2)

LESSON 2

Mass, Weight and Gravity**Do Now**

1. What is the difference between a scalar and a vector quantity? Give one example of each.
2. If an object is being pushed right with a force of 3 N and upwards with a force of 4 N what is the resultant force on it? (Use Pythagoras)
3. Why do objects fall?
4. On the Moon, gravitational field strength is about 1.6 N/kg. On Earth it is 9.8 N/kg. Suggest why the Moon has weaker gravity.

Part 1 of 3 | Gravity and Gravitational Field Strength

All objects attract each other due to the force of gravity.	1
The strength of gravity at the surface of a planet is determined by its mass.	2
Gravitational field strength (g) is a measure of the gravitational force per kilogram at a location.	3
The gravitational field strength on the surface of the Earth is 9.8 N/kg.	4
Weight is the force on an object due to gravity. Weight is a vector.	5
Mass is the amount of matter an object contains. Mass is a scalar and its SI unit is the kilogram (kg).	6
The mass of an object stays the same wherever it is. Its weight changes depending on the gravitational field strength.	7
The Moon has less mass than the Earth, so its gravitational field strength is less than the Earth's (~1.625 N/kg).	8

Questions

1. What is gravity? (1 mark)
2. What determines the strength of gravity at the surface of a planet? (1 mark)
3. What is the gravitational field strength at the surface of the Earth? (1 mark)
4. What is the difference between mass and weight? State whether each is a scalar or a vector. (3 marks)
5. Why would your weight be different on the Moon compared to on Earth, even though your mass stays the same? (2 marks)

Part 2 of 3 | Calculating Weight: $W = m \times g$

The weight of an object is calculated using: $W = m \times g$	1
Where: W = weight (in Newtons, N), m = mass (in kg), g = gravitational field strength (in N/kg).	2
On Earth: $g = 9.8$ N/kg (use this value unless told otherwise).	3

Questions

6. Write down the equation for weight. State the units for each quantity.

(2 marks)

7. Complete the tables for Arnie and Markey, filling in the missing weights and masses.

(3 marks)



Fig 2.1 — Arnie and Markey weigh themselves on different planets

Planet	Gravitational Field Strength (N/kg)	Arnie's Mass (kg)	Arnie's Weight (N)	Markey's Mass (kg)	Markey's Weight (N)
Mercury	3.78	30	113.4	0.5	
Venus	9.07	30			
Earth	9.8	30			
Moon	1.66	30			
Mars	3.77	30			
Jupiter	23.64	30	709.2		
Saturn	9.16	30			
Uranus	8.89	30			
Neptune	11.25	30			
Pluto	0.67	30			

8. Calculate the weight of each of the following objects on Earth ($g = 9.8 \text{ N/kg}$):

(a) mass = 5 kg

(b) mass = 70 kg

(c) mass = 0.5 kg

(d) mass = 2 000 kg.

(3 marks)

9. A Formula 1 car weighs 7 150 N. Calculate its mass. ($g = 9.8 \text{ N/kg}$)

(2 marks)

10. A cat weighs 42 N. Calculate its mass. ($g = 9.8 \text{ N/kg}$)

(2 marks)

11. A dog weighs 180 N. Calculate its mass. ($g = 9.8 \text{ N/kg}$)

(2 marks)

12. An iPad weighs 2.2 N. Calculate its mass. ($g = 9.8 \text{ N/kg}$)

(2 marks)

13. A Boeing 747 aeroplane weighs $1.9 \times 10^6 \text{ N}$. Calculate its mass. ($g = 9.8 \text{ N/kg}$)

(2 marks)

14. A man of mass 70 kg is standing on a planet where he weighs 1 750 N. Calculate the planet's gravitational field strength.

(2 marks)

15. The Curiosity Rover has a mass of 900 kg and weighs 3 400 N on Mars. Calculate Mars' gravitational field strength.

(2 marks)

Part 3 of 3 | Harder Calculations and Exam-Style Questions

Unit conversion: 1 kN = 1000 N; 1 tonne = 1000 kg; 1 g = 0.001 kg.	1
An iPhone weighs 1.2 N on Earth: mass = $1.2 / 9.8 = 0.122 \text{ kg} = 122 \text{ g}$.	2
A car weighs 12 kN = 12 000 N: mass = $12\,000 / 9.8 = 1\,224 \text{ kg}$.	3

Questions

- 16.** An iPhone has a weight of 1.2 N on Earth. Calculate its mass in grams. ($g = 9.8 \text{ N/kg}$) (2 marks)
- 17.** A bottle of water has a weight of 10 N on Earth. Calculate its mass in grams. (2 marks)
- 18.** A car has a weight of 12 kN on Earth. Calculate its mass in kg. (2 marks)
- 19.** A rocket of mass 133 000 kg has a weight of 500 kN on Mars. Calculate the gravitational field strength on Mars. (2 marks)

EXAM QUESTION — Q2: Mass, Weight and Gravity (9 marks)

Mark allocations shown as (n) following AQA convention.

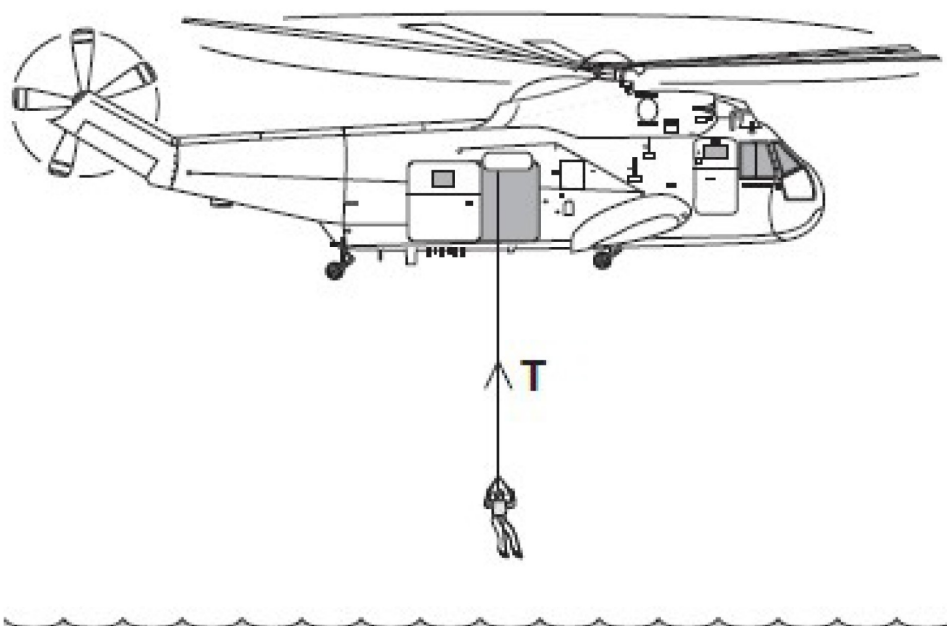

Fig 2.2 — A helicopter rescuing a person from the sea

- (a)** The mass of the rescued person is 72 kg. Calculate the weight of the person. ($g = 9.8 \text{ N/kg}$) Show clearly how you work out your answer. (2)
- (b)(i)** To lift the person to the helicopter, the electric motor transformed 21 600 J of energy usefully. Use the correct form of energy from: gravitational potential, heat, sound. Complete: "The electric motor transforms electrical energy to kinetic energy. The kinetic energy is then transformed into useful _____ energy." (1)
- (b)(ii)** It takes 50 seconds to lift the person. Calculate the power of the motor. Show your working and give the unit. (3)

LESSON 3

Resultant Force**Do Now**

1. What is the equation for weight? Define each symbol.
2. What is a scalar quantity? Give two examples.
3. What is a vector quantity? Give two examples.

Part 1 of 3 | Force Diagrams

The forces acting on any object can be shown using a force diagram. A force diagram uses labelled arrows to show all the forces acting on the object.	1
The direction of each arrow shows the direction of the force.	2
The length of each arrow is proportional to the size of the force.	3
The motion of the object depends on the resultant force: the single force that has the same effect as all forces combined.	4
The resultant force is found by adding all forces together, taking their direction into account.	5
To draw a resultant force: draw the arrows tip to tail; then draw a line from start to finish.	6

Questions

1. What does the length of an arrow in a force diagram show?
(1 mark)
2. What does the direction of an arrow in a force diagram show?
(1 mark)
3. Draw the resultant force of 3 N upward, 4 N to the right. Add one force onto the end of the other and draw a line from the start to the finish.
(2 marks)
4. For planes a–d in Fig 3.2 the wind is blowing in a different direction.
 - a) Sketch the resultant for each plane (remember the arrows must be *tip to tail*).
 - b) Explain which plane is accelerating the most?
 - c) Explain which plane is accelerating the least?
 (4 marks)

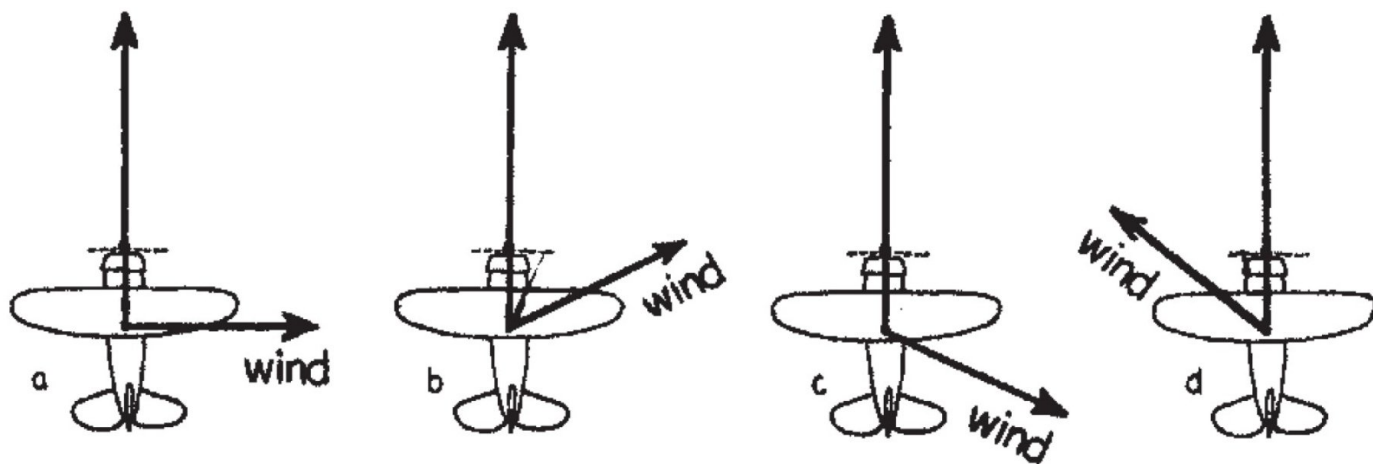

Fig 3.2 — Top view of an aeroplane blown off course by wind in four different directions

Part 2 of 3 | What the Resultant Means

If there is a resultant force, the object is accelerating.

1

If there is no resultant force, there is no acceleration.

2

No acceleration means the object is either stationary OR moving at a constant velocity.

3

Questions

5. A cat has a weight of 35 N and is standing still on a table.

- a) What direction does the weight of the cat act in?
- b) What is the name of the other force acting on the cat?
- c) What direction does that force act in?
- d) What is the size of that force?
- e) Draw two arrows on the diagram to represent the two forces acting on the cat. Label your arrows with the name and size of the force they show.



Fig 3.1 — Cat on a table

(3 marks)

6. In each of the examples below, calculate the **resultant force** and state whether the object is stationary, moving at a constant speed, or accelerating (and in which direction).

(3 marks)

<p>a)</p> <p>Overall force =</p> <p>The boat is</p>	<p>b)</p> <p>Overall force =</p> <p>The car is</p>	<p>c)</p> <p>Overall force =</p> <p>The skydiver is</p> <p>.....</p>
--	---	---

Part 3 of 3 | Resultant Force with Perpendicular Vectors

When forces are perpendicular we can also look at them separately. 1

Sometimes there is no horizontal force. 2

For example if you throw an object (and air resistance is negligible) there is only gravity acting on it. 3

Therefore it doesn't accelerate sideways at all — its horizontal velocity is constant. 4

If you shoot a bullet horizontally and drop a bullet they will hit the ground at the same time! 5

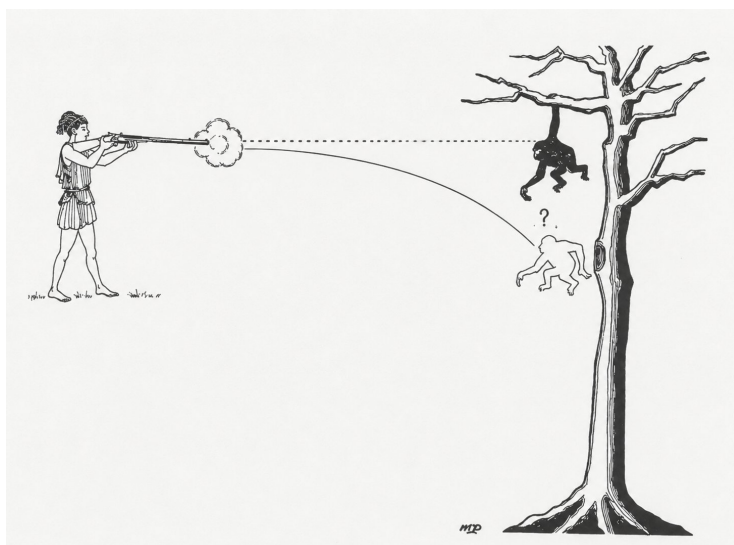

Fig 3.3 — The bullet and monkey fall at the same rate — the sideways motion of the bullet doesn't matter as it is perpendicular to gravity.

Questions

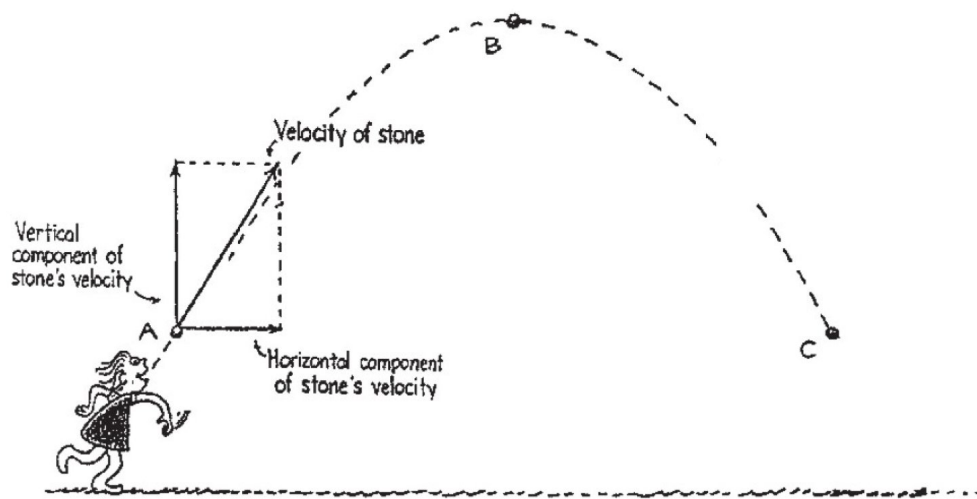

Fig 3.4 — Ug threw a rock!

7. If we ignore air resistance, we can assume that the horizontal velocity of an object does not change.
- Since there is no acceleration in the horizontal direction, how does the horizontal component of velocity compare for positions A, B and C?
 - What is the value of the vertical component of velocity at position B?
 - How does the vertical component at position C compare with that at position A?
 - Draw the resultant velocities at positions B and C.

(3 marks)

EXAM QUESTION — Q3: Resultant Force (10 marks)

Mark allocations shown as (n) following AQA convention.

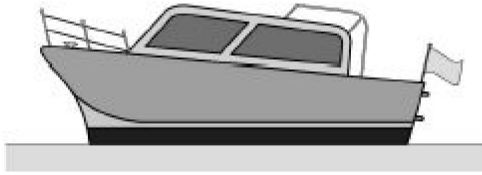

Fig 3.5 – A boat floating on the sea

(a) Fig 3.6 shows part of the free body diagram for the boat. Complete the free body diagram for the boat by adding the missing force.

(2)

(b) Calculate the mass of the boat. Use the information given in the figure. ($g = 9.8 \text{ N/kg}$) Give your answer to two significant figures.

(4)

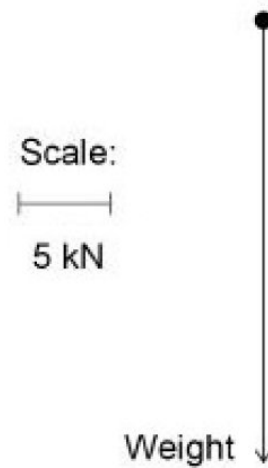

Fig 3.6 – Part of the free body diagram for the boat

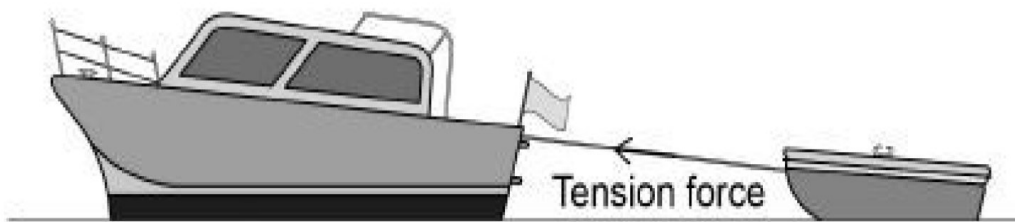

Fig 3.7 – The boat towing a dinghy

(c) The boat is towing a small dinghy. The tension force in the tow rope causes a horizontal force forwards of 150 N and a vertical force upwards of 50 N on the dinghy. Draw a vector diagram to determine the magnitude of the tension force in the tow rope and the direction of the force on the dinghy.

(4)

LESSON 4

Work Done and Energy Transfer**Do Now**

1. What is the unit of energy?
2. Name three stores of energy you have studied.
3. What does it mean when we say energy is "transferred"?
4. Calculate the weight of a person with a mass of 60 kg. ($g = 9.8 \text{ N/kg}$)

Part 1 of 3 | Work Done = Energy Transferred

When a force moves an object, work is done. Work done equals the energy transferred.	1
work done = energy transferred	2
The units of work done are the same as energy: Joules (J).	3
Work done is calculated using: $W = F \times s$	4
Where: W = work done (in Joules, J), F = force applied (in Newtons, N), s = distance travelled in the direction of the force (in metres, m).	5
To do work the force and distance must be in the same direction	6

Worked Example

A delivery worker pushes a heavy trolley along a warehouse floor. They apply a force of 50 N to push the trolley a distance of 8 m. Calculate the energy used.

V	$F = 50 \text{ N}$ $s = 8 \text{ m}$ $W = ?$
E	$W = F \times s$
S	$W = 50 \times 8$
S	$W = 400$
U	J (Joules)

Questions

1. What is work done? (1 mark)
2. Write the equation for work done. Include the units for each quantity. (2 marks)
3. Rearrange $W = F \times s$ to give equations for:
 - (a) force F ;
 - (b) distance s .(2 marks)

4. Calculate the work done if:

- (a) $F = 5 \text{ N}$, $s = 5 \text{ m}$.
- (b) $F = 150 \text{ N}$, $s = 0.1 \text{ m}$.
- (c) $F = 0.2 \text{ N}$, $s = 200 \text{ m}$.
- (d) $F = 2\,000 \text{ N}$, $s = 1.5 \text{ m}$.
- (e) $F = 800 \text{ N}$, $s = 25 \text{ m}$.
- (f) $F = 150\,000 \text{ N}$, $s = 0.5 \text{ m}$.

(3 marks)

5. What is the work done if we apply a 1.2 N force and move 4 m in the direction of the force?

(1 mark)

6. What is the work done if we apply a 7 N force and move 8 m in the direction of the force?

(1 mark)

7. A car drives with a force of 300 000 N over a distance of 200 m. What is the work done by the car?

(1 mark)

Part 2 of 3 | Finding Force and Distance

Example (finding force)

A weightlifter raises a bar, doing 720 J of work over a vertical distance of 2 m. Calculate the force.

V	$W = 720 \text{ J}$ $s = 2 \text{ m}$ $F = ?$
E	$F = \frac{W}{s}$
S	$F = \frac{720}{2}$
S	$F = 360$
U	N (Newtons)

Example (finding distance)

A gardener pushes a lawnmower with a force of 80 N, doing 400 J of work. How far does the mower travel?

V	$F = 80 \text{ N}$ $W = 400 \text{ J}$ $s = ?$
E	$s = \frac{W}{F}$
S	$s = \frac{400}{80}$
S	$s = 5$
U	m (metres)

Questions

8. Calculate the distance moved if:

- (a) $W = 20 \text{ J}$, $F = 10 \text{ N}$.
- (b) $W = 150 \text{ J}$, $F = 7.5 \text{ N}$.
- (c) $W = 200\,000 \text{ J}$, $F = 2 \text{ N}$.
- (d) $W = 300 \text{ J}$, $F = 0.5 \text{ N}$.
- (e) $W = 90\,000 \text{ J}$, $F = 4.5 \text{ N}$.
- (f) $W = 3\,000 \text{ J}$, $F = 9 \text{ N}$.

(3 marks)

9. Calculate the force if:

- (a) $W = 15 \text{ J}$, $s = 0.75 \text{ m}$.
- (b) $W = 450 \text{ J}$, $s = 225 \text{ m}$.
- (c) $W = 9\,000 \text{ J}$, $s = 3\,000 \text{ m}$.
- (d) $W = 5\,000 \text{ J}$, $s = 1\,250 \text{ m}$.
- (e) $W = 140 \text{ J}$, $s = 35 \text{ m}$.
- (f) $W = 800 \text{ J}$, $s = 0.2 \text{ m}$.

(3 marks)

10. What distance is moved if a force of 8 N is applied and work done is 90 J?

(2 marks)

11. What force is required to move 7 m if the work done is 9 J?

(2 marks)

Part 3 of 3 | Questions with Conversions

When quantities are given with prefixes (e.g. kN, km, kJ) you must convert to SI units before substituting into $W = F \times s$. 1

Use the table below. Remember: to convert to the base unit, multiply by the factor; to convert from the base unit, divide by the factor. 2

Prefix	Symbol	Multiply by	Example (force)	Example (distance)	Example (energy)
Giga	G	$\times 10^9$ ($\times 1\,000\,000\,000$)	1 GN = 1×10^9 N	1 Gm = 1×10^9 m	1 GJ = 1×10^9 J
Mega	M	$\times 10^6$ ($\times 1\,000\,000$)	1 MN = 1×10^6 N	1 Mm = 1×10^6 m	1 MJ = 1×10^6 J
kilo	k	$\times 10^3$ ($\times 1\,000$)	1 kN = 1 000 N	1 km = 1 000 m	1 kJ = 1 000 J
milli	m	$\times 10^{-3}$ ($\div 1\,000$)	1 mN = 0.001 N	1 mm = 0.001 m	1 mJ = 0.001 J

Worked Example

A truck engine exerts a force of 8 kN and moves the truck 300 m along a motorway. Calculate the work done.

V	$F = 8 \text{ kN} = 8 \times 1\,000 = 8\,000 \text{ N}$ $s = 300 \text{ m}$ $W = ?$
E	$W = F \times s$
S	$W = 8\,000 \times 300$
S	$W = 2\,400\,000$
U	J (= 2.4×10^6 J)

Questions

12. A crane lifts a load by applying a force of 3 kN over a distance of 8 m. Calculate the work done.

(2 marks)

13. A car engine produces a driving force of 5 kN and moves the car 600 m along a road. Calculate the work done by the engine.

(2 marks)

14. A rocket motor exerts a thrust of 200 kN as it travels 50 m along a test rig. Calculate the work done.

(2 marks)

15. A person pushes a heavy box with a force of 40 N along a corridor 3 km long. Calculate the work done.

(2 marks)

16. A cyclist pedals with a constant force of 60 N and travels 5 km. Calculate the work done by the cyclist.

(2 marks)

17. A snail pushes against a leaf with a force of 0.04 N and travels 250 cm. Calculate the work done.

(2 marks)

- 18.** A train engine exerts a force of 6 kN and travels 4 km along a track. Calculate the work done. (2 marks)
- 19.** A tractor pulls with a force of 8 kN over a distance of 2 km. Calculate the work done. (2 marks)
- 20.** A ship's propeller exerts a thrust of 50 kN and the ship travels 6 km. Calculate the work done. (2 marks)
- 21.** A bulldozer does 720 kJ of work while pushing rubble. The driving force of the bulldozer is 9 kN. Calculate the distance moved by the bulldozer. (3 marks)
- 22.** An electric car does 600 kJ of work travelling 3 km along a motorway. Calculate the driving force of the car. (3 marks)

EXAM QUESTION — AQA June 2018, Paper 1 (8463/1H), Question 5

Mark allocations shown as (n) following AQA convention.

Two students push a car that has broken down. Student A pushes with a force of 180 N. Student B pushes with a force of 120 N. Both students push in the same direction.

- (a)** Write down the equation that links work done, force and distance moved. (1)
- (b)** Calculate the total force exerted by both students on the car. (1)
- (c)** The car is pushed 6 m along the road.
Calculate the work done by both students.
Give the unit. (3)
- (d)** One student then pushes the car back 6 m on their own with a force of 200 N.
Calculate the work done by the single student.
Give the unit. (2)
- (e)** Compare the work done in part (c) with the work done in part (d).
Explain the difference. (2)

LESSON 5

Newton's Laws

Do Now

1. What is meant by a "resultant force"?
2. If the resultant force on an object is zero, what can you say about its motion?
3. State the equation linking work done, force and distance.
4. An object of mass 5 kg is pushed with a force of 20 N. Without using the equation $F = ma$, predict what happens to the object.

Part 1 of 5 | Newton's First Law

Definition: for there to be acceleration, there must be an unbalanced (resultant) force. 1

In other words, if the resultant force acting on an object is zero, its motion does not change. There are two cases: 2

If the object is stationary, it remains stationary. 3

If the object is moving, it continues to move at the same speed and in the same direction — so it continues to move at the same velocity. 4

(a) Stationary object

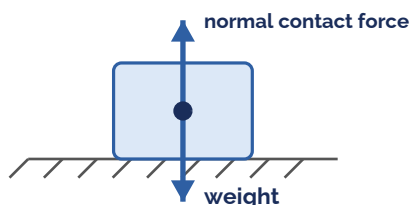

balanced forces stays at rest

(b) Constant velocity

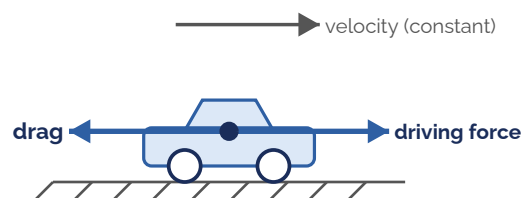

balanced forces same velocity

Fig 5.1 — When forces are balanced (resultant = 0) the motion does not change: an object stays at rest, or keeps moving at the same velocity.

Questions

1. State Newton's First Law of motion. (2 marks)
2. A car is parked on a flat, level road.
 - (a) Is there a resultant force acting on the car?
 - (b) Describe the motion of the car. (2 marks)
3. A train travels in a straight line at a constant speed of 30 m/s. What does this tell you about the resultant force on the train? Explain your answer. (2 marks)

4. A spacecraft is moving through deep space with its engines switched off, far from any planet or star, so that no forces act on it. Describe how it will move and explain why, using Newton's First Law.

(2 marks)

5. For each object, state whether the resultant force is zero or not zero:

- (a) a parked lorry.
- (b) a car speeding up.
- (c) a skydiver falling at a constant (terminal) velocity.
- (d) a cyclist slowing down.

(2 marks)

Part 2 of 5 | Newton's Second Law

Newton's Second Law: when there is a resultant force, the object accelerates. The acceleration is directly proportional to the resultant force and inversely proportional to the mass. 1

This gives the equation: $F = m \times a$ 2

Where: F = resultant force (in N), m = mass (in kg), a = acceleration (in m/s^2). 3

A bigger resultant force gives a bigger acceleration. A bigger mass gives a smaller acceleration. 4

A resultant force makes a mass accelerate: $F = m \times a$

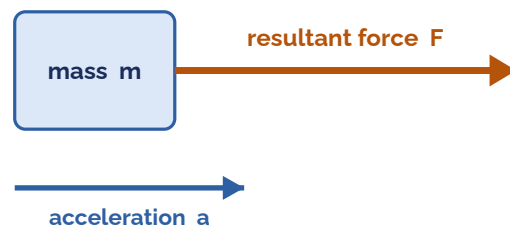

Fig 5.2 — A resultant force F acting on a mass m produces an acceleration a in the direction of the force, where $F = m \times a$.

Worked Example

A trolley of mass 8 kg is pushed along a smooth floor and accelerates at 3 m/s^2 . Calculate the resultant force on the trolley.

V	$m = 8 \text{ kg}$ $a = 3 \text{ m/s}^2$ $F = ?$
E	$F = m \times a$
S	$F = 8 \times 3$
S	$F = 24$
U	N (Newtons)

Questions

6. State Newton's Second Law of motion.

(2 marks)

7. Give the units and symbol for each term in $F = m \times a$:

- (a) Force (F)
- (b) Mass (m)
- (c) Acceleration (a).

(3 marks)

8. Work out the force in each of the following:

- (a) mass = 4 kg, acceleration = 2 m/s^2 .
 (b) mass = 150 kg, acceleration = 3 m/s^2 .
 (c) mass = 20 kg, acceleration = 2.7 m/s^2 .
 (d) mass = 500 kg, acceleration = 5 m/s^2 .

(3 marks)

9. How much force is needed to accelerate a 66 kg skier at 2 m/s^2 ?

(2 marks)

10. What is the resultant force on a 1 000 kg lift that is accelerating at 9.8 m/s^2 ?

(2 marks)

11. A 50 kg skater pushed by a friend accelerates at 5 m/s^2 . How much force did the friend apply?

(2 marks)

Part 3 of 5 | Newton's Second Rearranged

Sometimes the resultant force is known and we need to find the mass or the acceleration instead. 1

Always start from $F = m \times a$, then rearrange to make the unknown quantity the subject. 2

The two worked examples below show how: one finds the mass, the other finds the acceleration. 3

Remember to convert grams to kilograms first ($1 \text{ g} = 0.001 \text{ kg}$, so divide grams by 1 000). 4

Example (finding mass)

A resultant force of 18 N makes an object accelerate at 6 m/s^2 . Calculate the mass of the object.

V	$F = 18 \text{ N}$ $a = 6 \text{ m/s}^2$ $m = ?$
E	$F = m \times a$
S	$18 = m \times 6$
S	$m = \frac{18}{6} = 3$
U	kg (kilograms)

Example (finding acceleration)

A resultant force of 40 N acts on a 5 kg box. Calculate the acceleration of the box.

V	$F = 40 \text{ N}$ $m = 5 \text{ kg}$ $a = ?$
E	$F = m \times a$
S	$40 = 5 \times a$
S	$a = \frac{40}{5} = 8$
U	m/s^2

Questions

12. Work out the mass in each of the following:

- (a) $a = 5 \text{ m/s}^2$, $F = 12 \text{ N}$.
 (b) $a = 25 \text{ m/s}^2$, $F = 200 \text{ N}$.
 (c) $a = 15 \text{ m/s}^2$, $F = 3 \text{ N}$.
 (d) $a = 0.5 \text{ m/s}^2$, $F = 3 \text{ N}$.

(3 marks)

13. Work out the acceleration in each of the following:

- (a) $F = 20 \text{ N}$, $m = 5 \text{ kg}$.
 (b) $F = 7 \text{ N}$, $m = 14 \text{ kg}$.
 (c) $F = 2\,000 \text{ N}$, $m = 1\,250 \text{ kg}$.

(d) $F = 0.75 \text{ N}$, $m = 0.45 \text{ kg}$.

(3 marks)

14. What is the acceleration of a 50 kg object pushed with a resultant force of 500 N?

(2 marks)

15. A resultant force of 250 N is applied to an object that accelerates at 5 m/s^2 . What is the mass of the object?

(2 marks)

16. A resultant force of 20 N acts upon a 500 g block. Calculate the acceleration of the block.

(2 marks)

Part 4 of 5 | Newton's Third Law

Newton's Third Law: whenever one object exerts a force on a second object, the second object exerts an equal and opposite force back on the first. 1

These two forces are called an action–reaction pair. They are equal in size, opposite in direction, and the same type of force. 2

Importantly, the two forces act on different objects, so they never cancel each other out. 3

Example: a book pushes down on a table; the table pushes up on the book with an equal and opposite force. 4

Newton's Third Law: an action–reaction pair

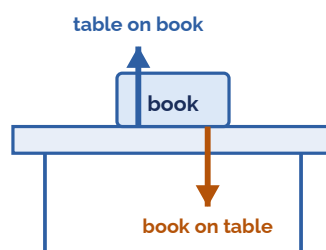

equal size • opposite direction • act on different objects

Fig 5.3 – An action–reaction pair. The book pushes down on the table and the table pushes up on the book with a force that is equal in size but opposite in direction.

Questions

17. State Newton's Third Law of motion and give an example.

(2 marks)

18. A swimmer pushes backwards against the water with a force of 200 N.

(a) Describe the force the water exerts on the swimmer (size and direction).

(b) In which direction does the swimmer move?

(2 marks)

19. A book rests on a table and pushes down on the table with a force of 8 N.

(a) State the size and direction of the force the table exerts on the book.

(b) Name the law that explains this.

(2 marks)

20. A rocket pushes hot gas downwards out of its engines. Explain, using Newton's Third Law, how this makes the rocket move upwards.

(2 marks)

Part 5 of 5 | Newton's Laws Acting Together

Real situations involve several forces at once. To solve them, work in two steps. 1

Step 1: find the resultant force. If it is zero the object is at rest or at constant velocity (Newton's First Law). 2

Step 2: if the resultant force is not zero, use $F = m \times a$ with the resultant force (Newton's Second Law) to find the acceleration. 3

Remember to use the resultant force — not just one of the forces — and convert grams to kilograms first. 4

Several forces act at once

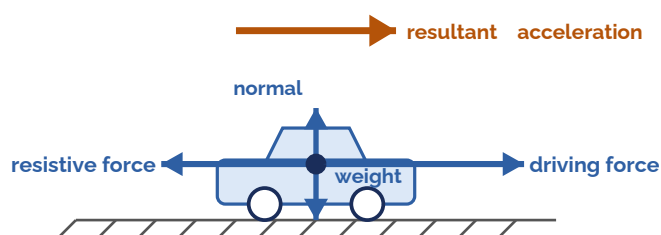

Fig 5.4 — Several forces act on a moving car. The vertical forces are balanced; the horizontal forces give a resultant that accelerates the car ($F = m \times a$).

Questions

21. A 200 g block is pulled across a table by a horizontal force of 40 N, with a frictional force of 8 N opposing the motion.

(a) Calculate the resultant force.

(b) Calculate the acceleration of the block.

(3 marks)

22. An object of mass 300 g is falling in air and experiences a force due to air resistance of 1.5 N. Determine the net (resultant) force acting on the object and calculate its acceleration. ($g = 9.8 \text{ N/kg}$)

(3 marks)

23. A 60 kg person on a 15 kg sled is pushed with a force of 300 N. What will be the person's acceleration?

(2 marks)

24. A 1 000 kg car has a driving force of 3 000 N and experiences 1 000 N of resistive forces.

(a) Calculate the resultant force.

(b) Calculate the acceleration of the car.

(3 marks)

EXAM QUESTION — Q5: Newton's Laws (9 marks)

Mark allocations shown as (n) following AQA convention.

Several forces act at once

Fig 5.5 – The two horizontal forces acting on the car.

A car of mass 1 200 kg is driven along a straight, level road. Figure 5.5 shows the two horizontal forces acting on the car.

- (a)** When the car is accelerating, the driving force is ___ the resistive force. Choose one: smaller than / equal to / larger than. (1)
- (b)** At one moment the driving force is 4 200 N and the resistive force is 1 800 N. Calculate the resultant force acting on the car. (1)
- (c)** The mass of the car is 1 200 kg. Calculate the acceleration of the car at this moment. Use the equation $F = m \times a$. (3)
- (d)** The driver adds heavy luggage so the car's total mass increases. The driving force and resistive force are unchanged. Explain what happens to the acceleration of the car. (2)
- (e)** As the car speeds up the resistive force increases, until the car travels at a constant maximum speed. Explain, in terms of the forces acting, why the car can no longer accelerate. (2)

LESSON 6

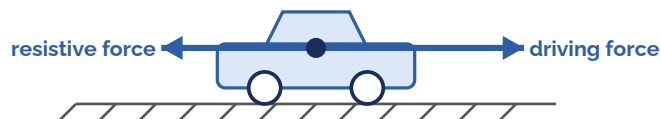
Required Practical 7: Newton's Second Law

Do Now

1. State Newton's Second Law of motion.
2. Write the equation $F = m \times a$ and rearrange it to find a .
3. What is a "directly proportional" relationship? How would it appear on a graph?
4. Why might a ramp be used in a Newton's Second Law experiment?

Part 1 of 3 | Aim, Apparatus and Setup

This required practical investigates how the acceleration of a trolley depends on the resultant force applied to it, while the mass is kept constant. It tests Newton's Second Law, $F = m \times a$.

Apparatus: a dynamics trolley on a low-friction runway, a length of string, a pulley at the edge of the bench, slotted masses on a hanger, and light gates connected to a data logger (or a ticker timer).

The accelerating force is provided by the weight of the hanging masses: force = mass of hanger \times g .

The runway is tilted slightly (or an air track is used) to compensate for friction, so the only resultant force on the trolley is from the hanging masses.

Independent variable: the force applied. Dependent variable: the acceleration. Control variable: the total mass being accelerated.

Hypothesis: the acceleration will increase as the force increases. This is because $F = m \times a$ — a larger resultant force produces a larger acceleration.

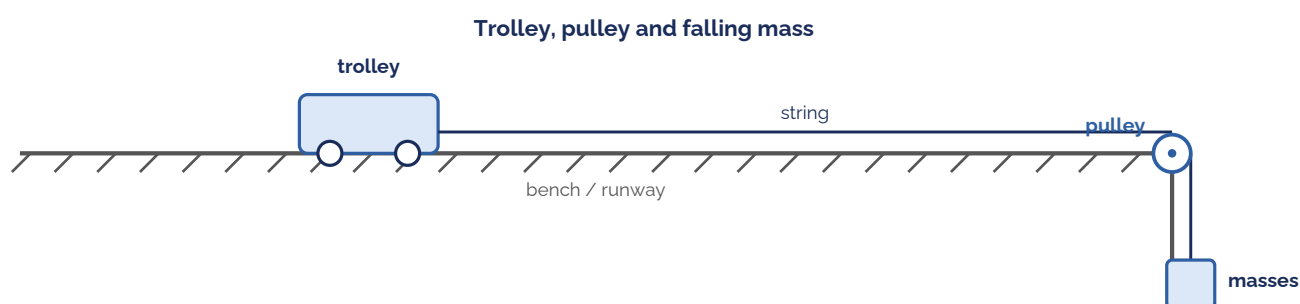

Fig 6.1 — The trolley is pulled by a string that runs over a pulley to a falling mass, which provides the accelerating force.

Questions

1. Write a hypothesis for this experiment. Use "I think that the car will accelerate ___ when more ___ are applied to the string. This is because Newton's ___ law says that the force is equal to the mass multiplied by the ___." (2 marks)
2. Complete the equation used to calculate acceleration from time: $a = \frac{v}{t}$ (1 mark)
3. Why should the same trolley be used throughout the investigation? (1 mark)

4. Why should the students use a sloping runway? Choose one: (a) To reduce the effect of friction. (b) To decrease the acceleration. (c) To stop the trolley rolling back.

(1 mark)

Part 2 of 3 | Method and Measuring the Acceleration

Method: set up the trolley on the runway with the string running over the pulley to the hanging masses. Mark a fixed distance for the trolley to travel. 1

Release the trolley from rest and find its acceleration. Over a fixed distance from rest: $a = (2 \times s) / t^2$. With two light gates and an interrupt card: $a = (v - u) / t$. 2

To change the force without changing the total mass, move masses one at a time from the trolley to the hanger. The total mass being accelerated stays the same, so only the force changes. 3

Repeat each measurement and take a mean to improve reliability and to spot anomalous results. 4

Record the force applied and the matching acceleration in a results table. 5

Measuring acceleration with light gates

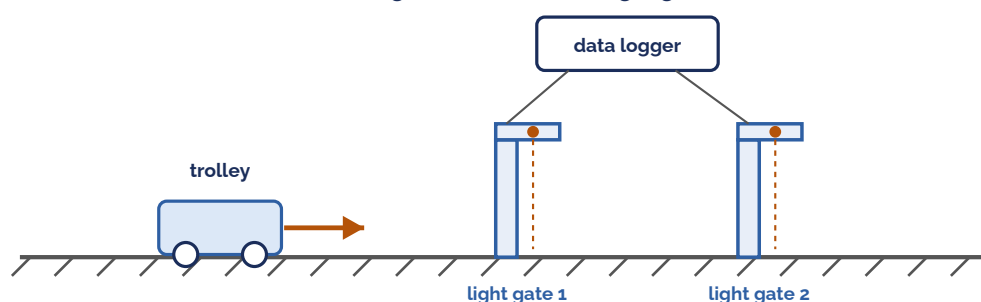

Fig 6.2 – Light gates linked to a data logger measure the trolley's velocity at two points, which gives its acceleration.

Questions

5. Describe the method the students could have used for this investigation. (Write your answer in numbered steps.) (6 marks)

6. To increase the force without changing the total mass, the students moved masses from the trolley onto the hanger. Explain why this keeps the total mass constant. (2 marks)

7. Explain why the students should repeat each measurement and calculate a mean. (2 marks)

8. The students used two light gates and a data logger. Explain how these can be used to find the acceleration of the trolley. (2 marks)

Results table – record your results during the practical below:

Mass (kg)	Force (N)	Time (s)	Acceleration (m/s^2)
0.01	0.1		
0.02	0.2		
0.03	0.3		
0.04	0.4		
0.05	0.5		
0.06	0.6		
0.07	0.7		
0.08	0.8		

Part 3 of 3 | Analysis and Conclusions

Plot a graph of acceleration (y-axis) against force (x-axis) and draw a line of best fit. 1

If acceleration is directly proportional to force, the graph is a straight line through the origin (Fig 6.3). This confirms Newton's Second Law when the mass is kept constant. 2

A second investigation keeps the force constant and varies the mass of the trolley by adding masses to it. 3

Plotting acceleration against mass gives a curve (Fig 6.4): as the mass increases, the acceleration decreases. Acceleration is inversely proportional to mass. 4

Together these results show $F = m \times a$: acceleration is proportional to the force and inversely proportional to the mass. 5

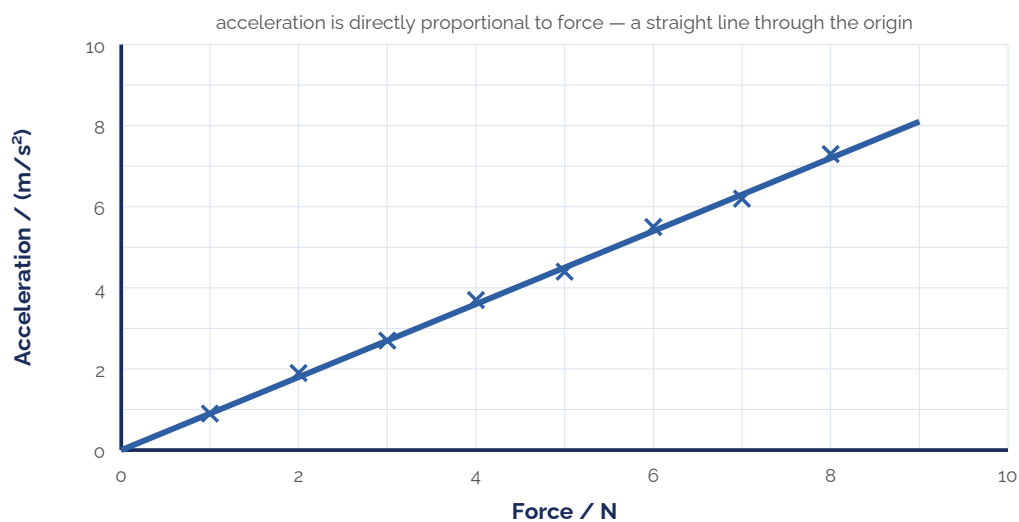

Fig 6.3 — Constant mass: acceleration against force is a straight line through the origin.

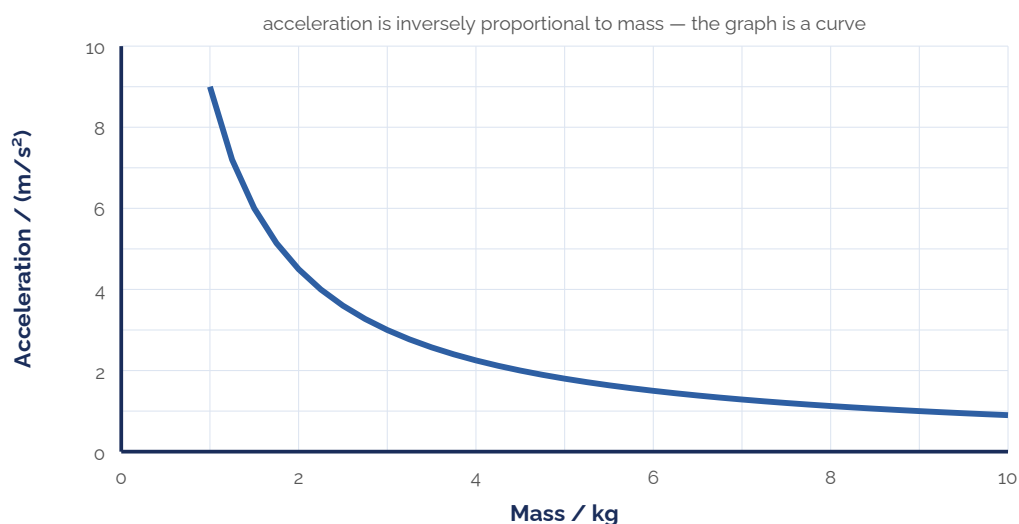

Fig 6.4 — Constant force: acceleration against mass is a curve — acceleration falls as the mass rises.

Questions

9. Conclusion: Fill in the missing words using the word bank below. Word bank: accelerated – decreased – larger – second – proportional As I added more masses the time taken for the car to travel one metre _____. This is because the car _____ faster because of a _____ force. My graph shows that the force is directly _____ to the acceleration, and proves Newton's _____ law.

(3 marks)

10. Hypothesis A states: "The acceleration of the trolley is directly proportional to the force applied." Predict what would happen to the acceleration if the force applied is doubled.

(1 mark)

11. Why is it difficult to make a valid prediction using hypothesis B: "Changing the force applied to the trolley will change the acceleration"?

(1 mark)

12. Explain why hypothesis A gives a better explanation of the results than hypothesis B.

(2 marks)

13. In the second investigation the force was kept constant and the mass of the trolley was increased. Describe and explain what happens to the acceleration.

(2 marks)

EXAM QUESTION — Q6: Required Practical — Newton's Second Law (9 marks)

Mark allocations shown as (n) following AQA convention.

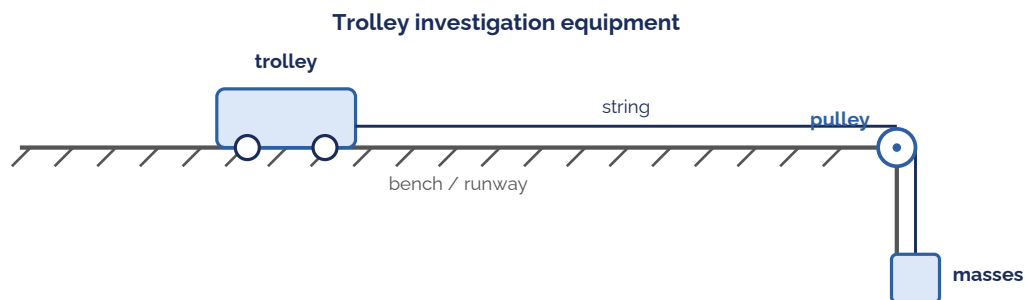

Fig 6.5 — The equipment used for the trolley investigation.

Students investigate how the acceleration of a trolley depends on the force applied. Figure 6.5 shows the equipment they use. The accelerating force is the weight of the masses on the hanger.

(a) Consider hypothesis A: "The acceleration of the trolley is directly proportional to the force applied." Predict what happens to the acceleration if the force is doubled.

(1)

(b) The students hang a mass of 100 g on the hanger. Calculate the accelerating force this provides. ($g = 10 \text{ N/kg}$)

(2)

(c) Write a list of any other equipment the students will need, beyond what is shown in Fig 6.5.

(2)

(d) The students used the same trolley throughout the investigation. Suggest why.

(2)

(e) The students' results are shown as a graph. Explain why hypothesis A gives a better explanation of the results than hypothesis B: "Changing the force will change the acceleration."

(2)

LESSON 7

Terminal Velocity

Do Now

1. If the resultant force on an object is zero, what can you say about its motion?
2. A skydiver jumps from a plane. Name the two main forces acting on them during the fall.
3. Which force increases as the skydiver falls faster?
4. What does it mean if two forces are "balanced"?

Part 1 of 3 | The Forces on a Falling Object

When an object falls through the air, two forces act on it: its weight (downwards, caused by gravity) and air resistance (upwards, opposing its motion). 1

The weight stays the same throughout the fall. The air resistance increases as the object moves faster. 2

Just after the object starts to fall, air resistance is small, so weight is greater than air resistance. There is a resultant force downwards, so the object accelerates. 3

As it speeds up, air resistance increases, so the resultant force gets smaller and the acceleration decreases. 4

Eventually air resistance increases until it is equal to the weight. The resultant force is now zero, so there is no acceleration. The object falls at a steady speed called the terminal velocity. 5

(a) Just after jumping

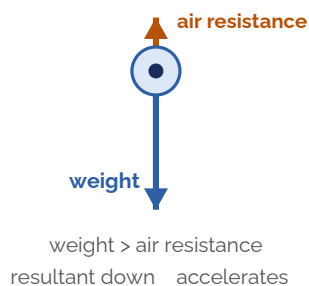

(b) At terminal velocity

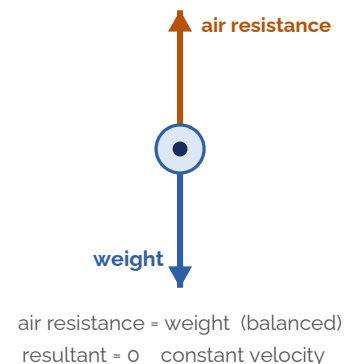

Fig 7.1 – Forces on a falling object: just after jumping (unbalanced) and at terminal velocity (balanced).

Questions

1. Name the two forces acting on a skydiver as they fall through the air, and state the direction of each. (2 marks)
2. Explain why a skydiver accelerates just after jumping from the plane. (2 marks)
3. As the skydiver speeds up, state what happens to each of the following:
 - (a) the air resistance;
 - (b) the resultant force;
 - (c) the acceleration.

(3 marks)

4. What is meant by the term "terminal velocity"?

(2 marks)

5. State what is true about the forces acting on an object when it is falling at its terminal velocity.

(1 mark)

Part 2 of 3 | The Stages of a Skydive

Stage A: The skydiver jumps from the plane. Weight pulls her down. Air resistance is very small at first, so she starts to accelerate.

1

Stage B: As she falls faster, air resistance increases and acts in the opposite direction to her weight.

2

Stage C: Air resistance continues to increase until it equals her weight. The forces are balanced, so she falls at a constant speed – her terminal velocity.

3

Stage D: She opens her parachute. There is now a very large upward air resistance force, so she decelerates (slows down).

4

Stage E: As she slows down, air resistance decreases until it equals her weight again. She reaches a new, slower terminal velocity and lands safely.

5

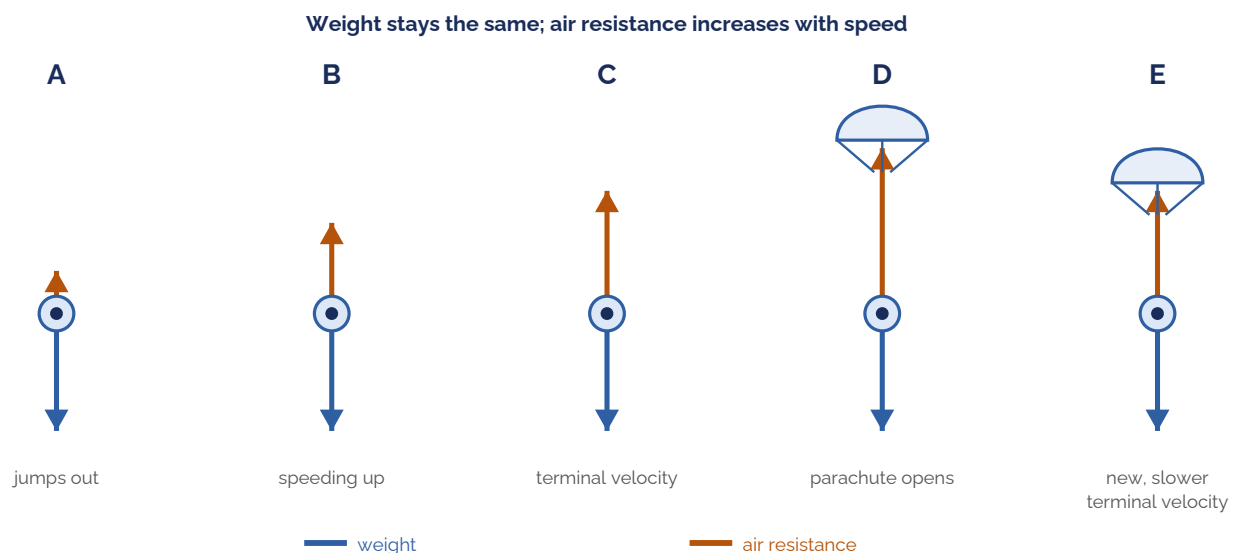

Fig 7.2 – The stages of a skydive. Weight is constant; air resistance changes with speed and with the open parachute.

Questions

6. Fill in the missing words: A The skydiver jumps out of the plane and the downward force of her ___ pulls her down. Her air resistance at the start is very ___ but soon she starts to ___.

(2 marks)

7. Fill in: B As she accelerates, the air resistance force ___ and acts in the opposite direction to her ___.

(1 mark)

8. Fill in: C As she accelerates faster, the air resistance force continues to ___ until eventually it is the ___ as her weight. She is now moving at a ___ speed, called her ___ velocity. The two forces are ___.

(2 marks)

9. Fill in: D She opens her parachute. There is now a very ___ air resistance force, so she starts to ___ (slow down).

(1 mark)

10. Fill in: E As she decelerates, the air resistance force ___ until it is the ___ size as her weight. She is now again falling at a ___ speed, but has a new and slower ___ velocity.

(2 marks)

Part 3 of 3 | Velocity-Time Graphs

A velocity-time graph shows how the speed of a falling skydiver changes over time. Its shape tells the whole story of the jump. 1

A steep, rising line means the skydiver is accelerating. A horizontal line (zero gradient) means zero acceleration – a constant speed, or terminal velocity. 2

When the parachute opens, the line falls steeply: the skydiver is decelerating. It then levels off at a lower height – a new, slower terminal velocity – before reaching zero on landing. 3

Opening the parachute greatly increases the cross-sectional area, so air resistance increases sharply. The larger parachute means air resistance equals the weight at a lower speed. 4

Time (s)	0	5	10	15	20	25	30	35	40	45	50	55	60
Velocity (m/s)	0	28	43	48	50	50	50	49	12	10	10	10	0

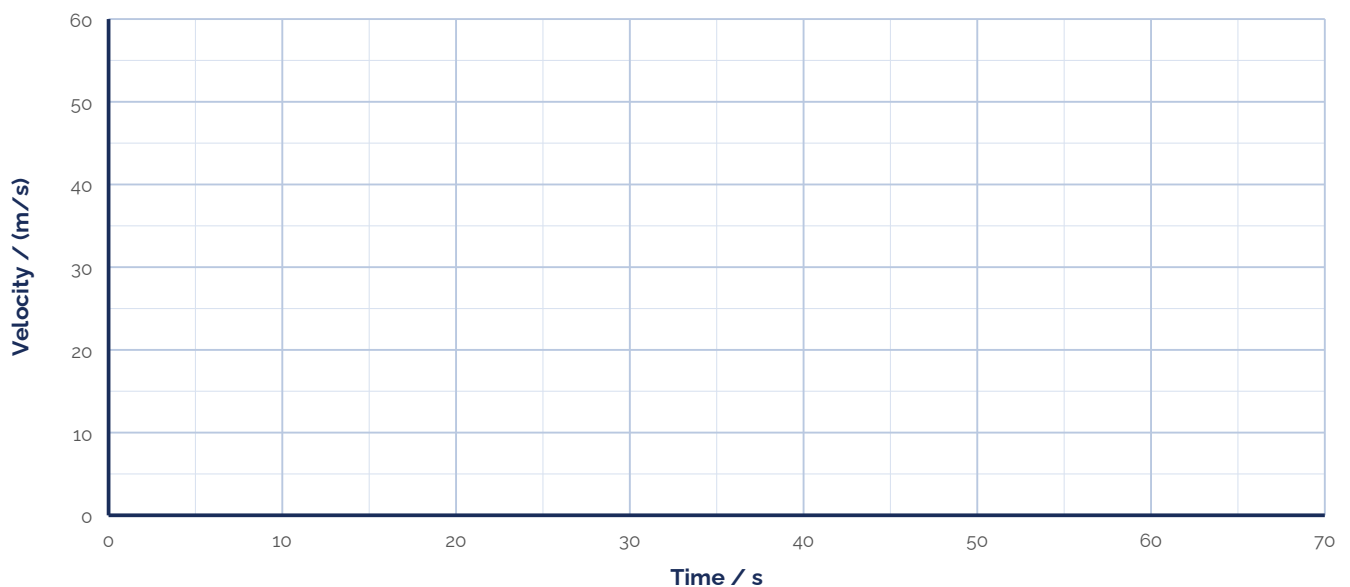

Fig 7.3 – Grid for plotting the skydiver's velocity-time graph.

Questions

- 11.** The table above shows the velocity of a skydiver over time. Plot the points on the grid (Fig 7.3) and draw a smooth curve through them. Label these parts of the journey on your graph: 1 acceleration, 2 terminal velocity, 3 parachute opens, 4 deceleration, 5 lands. (4 marks)
- 12.** Using the idea of forces, explain why the skydiver reaches a terminal velocity. (3 marks)
- 13.** Using the idea of forces, explain why opening the parachute reduces the skydiver's terminal velocity. (3 marks)

EXAM QUESTION — Q7: Terminal Velocity (9 marks)

Mark allocations shown as (n) following AQA convention.

A parachutist of mass 80 kg jumps from a helicopter. Figure 7.4 shows how their vertical velocity changes from the moment they jump until they land. **gravitational field strength, $g = 9.8 \text{ N/kg}$**

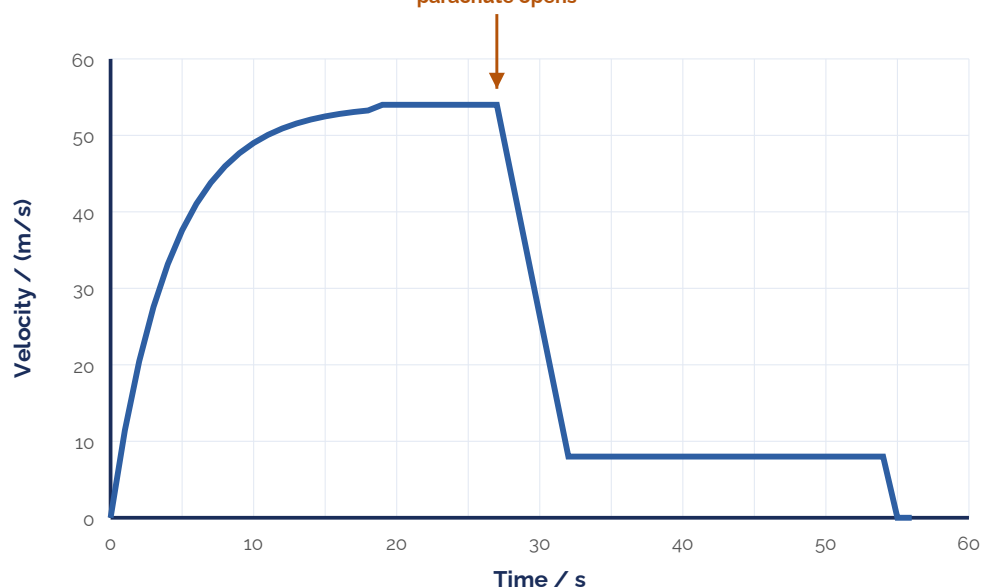

Fig 7.4 — Vertical velocity of the parachutist against time.

- (a) Calculate the weight of the parachutist. Show your working and give the unit. (3)
- (b) Before the parachute opens, the parachutist reaches a terminal velocity. Explain, in terms of the forces acting, why a terminal velocity is reached. (3)
- (c) Using the graph and the idea of forces, explain what happens to the parachutist's motion when the parachute opens. (3)

LESSON 8

Momentum

Do Now

1. What is the difference between speed and velocity?
2. State Newton's Second Law of motion ($F = m \times a$).
3. A 2 kg object accelerates at 3 m/s^2 . Calculate the force acting on it.
4. Why is velocity a vector quantity but speed is a scalar?

Part 1 of 3 | Momentum: $p = m \times v$

Any mass that is moving carries momentum. 1

Momentum is calculated using: $p = m \times v$ 2

Where: p = momentum (in kg m/s), m = mass (in kg), v = velocity (in m/s). 3

Because the equation contains velocity (a vector), momentum is also a vector: it acts in the direction the object is moving. 4

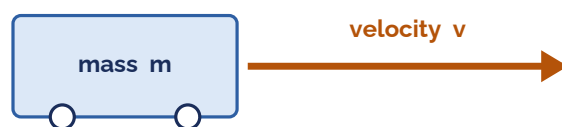
Momentum of a moving object: $p = m \times v$ 

momentum is a vector – it acts in the direction of motion

Fig 8.1 – Momentum $p = m \times v$ is a vector, acting in the direction of motion.

Worked Example

Dr Edmunds drops his iPad. Just before it hits the ground it is travelling at 5 m/s . The iPad has a mass of 500 g . Calculate its momentum.

V	$v = 5 \text{ m/s}$ $m = 500 \text{ g} = 0.5 \text{ kg}$ $p = ?$
E	$p = m \times v$
S	$p = 0.5 \times 5$
S	$p = 2.5$
U	kg m/s

Questions

1. What is momentum? State whether it is a scalar or a vector quantity, and explain why.

(2 marks)

2. Write the equation for momentum. State the units for each quantity. (2 marks)
3. Calculate the momentum if:
 (a) $m = 0.3 \text{ kg}$, $v = 7 \text{ m/s}$.
 (b) $m = 5 \text{ kg}$, $v = 12 \text{ m/s}$. (2 marks)
4. Calculate the momentum of a football of mass 500 g travelling at 10 m/s. (2 marks)
5. Calculate the momentum of a mouse of mass 400 g running through the grass at 3 m/s. (2 marks)

Part 2 of 3 | Rearranging: Finding Mass and Velocity

- If the momentum is known, you can still find a missing mass or velocity — always starting from $p = m \times v$. 1
- Write $p = m \times v$, substitute in the values you know, and then rearrange to make the unknown the subject. 2
- Do not learn a separate rearranged formula: substitute first, rearrange afterwards. 3

Example (finding mass)

A trolley has a momentum of 600 kg m/s while moving at 12 m/s. Calculate its mass.

V	$p = 600 \text{ kg m/s}$ $v = 12 \text{ m/s}$ $m = ?$
E	$p = m \times v$
S	$600 = m \times 12$
S	$m = \frac{600}{12}$
S	$m = 50$
U	kg

Example (finding velocity)

A 6 kg bowling ball has a momentum of 90 kg m/s. Calculate its velocity.

V	$p = 90 \text{ kg m/s}$ $m = 6 \text{ kg}$ $v = ?$
E	$p = m \times v$
S	$90 = 6 \times v$
S	$v = \frac{90}{6}$
S	$v = 15$
U	m/s

Questions

6. Calculate the velocity if:
 (a) $p = 1.5 \text{ kg m/s}$, $m = 0.3 \text{ kg}$.
 (b) $p = 17 \text{ kg m/s}$, $m = 8.5 \text{ kg}$. (2 marks)
7. Calculate the mass if:
 (a) $p = 1\,400 \text{ kg m/s}$, $v = 20 \text{ m/s}$.
 (b) $p = 1\,800\,000 \text{ kg m/s}$, $v = 9 \text{ m/s}$. (2 marks)
8. An athlete running at 8 m/s has a momentum of 520 kg m/s. What is her mass? (2 marks)
9. Cristiano Ronaldo kicks a football with a momentum of 50 kg m/s. If the mass of the football is 500 g, what velocity has he kicked it at?

- (2 marks)
10. Dr Edmunds runs with a momentum of 700 kg m/s. If his velocity is 10 m/s, what is his mass?
(2 marks)
11. A rocket has a momentum of 700 000 000 kg m/s and travels at 1 400 m/s. What is its mass?
(2 marks)

Part 3 of 3 | Momentum with Unit Conversions

Always convert quantities to SI units before using $p = m \times v$.	1
Useful conversions: 1 tonne = 1 000 kg; 1 kg = 1 000 g; 1 km = 1 000 m; 1 mile = 1 600 m.	2
To convert a speed in km/h to m/s, multiply by 1 000 then divide by 3 600.	3
If a speed is not given directly, find it from distance and time: $v = s / t$.	4
Remember to convert minutes and hours into seconds (1 minute = 60 s, 1 hour = 3 600 s).	5

Questions

12. A car that weighs 2 tonnes is travelling at 20 m/s. Calculate its momentum.
(2 marks)
13. A train is travelling at 80 mph and has a mass of 100 tonnes. Calculate its momentum. (1 mile = 1 600 m)
(2 marks)
14. An eagle travels 150 m in 12 seconds and has a mass of 4 kg. Calculate its momentum.
(2 marks)
15. An aeroplane of mass 200 tonnes travels 900 km in 90 minutes. Calculate its momentum.
(2 marks)
16. A car has a momentum of 24 000 kg m/s while travelling at 72 km/h. Calculate its mass.
(3 marks)
17. A train travelling at 144 km/h has a momentum of 1 600 000 kg m/s. Calculate its mass. Give your answer in tonnes.
(3 marks)
18. A motorbike and rider have a momentum of 4 500 kg m/s at a speed of 54 km/h. Calculate their total mass.
(3 marks)
19. A sprinter running at 36 km/h has a momentum of 600 kg m/s. Calculate the sprinter's mass.
(3 marks)
20. A bullet of mass 20 g has a momentum of 8 kg m/s. Calculate its velocity.
(3 marks)
21. A small boat of mass 2 tonnes has a momentum of 30 000 kg m/s. Calculate its velocity.
(3 marks)
22. A tennis ball of mass 60 g has a momentum of 3.6 kg m/s. Calculate its velocity.
(3 marks)
23. A goods wagon of mass 5 tonnes has a momentum of 40 000 kg m/s. Calculate its velocity.
(3 marks)

EXAM QUESTION — Q8: Momentum (5 marks)

Mark allocations shown as (n) following AQA convention.

Figure 8.2 shows a car of mass 900 kg travelling along a straight, level road at 12 m/s.

A car travelling along a straight, level road

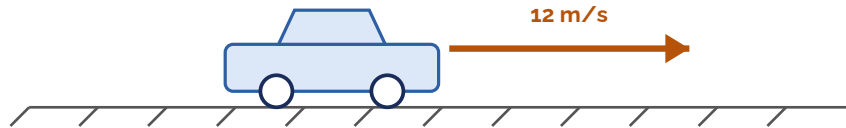

Fig 8.2 — A car of mass 900 kg travelling at 12 m/s.

- (a)** State what is meant by the momentum of a moving object. (1)
- (b)** Calculate the momentum of the car. Show your working and give the unit. (2)
- (c)** The car slows down and stops at a set of traffic lights. State the momentum of the car when it is stationary, and explain your answer. (2)

LESSON 9

Conservation of Momentum

Do Now

1. Write the equation for momentum. State the units.
2. Calculate the momentum of a 1 200 kg car travelling at 15 m/s.
3. What is the momentum of a stationary object? Explain why.
4. What is Newton's Third Law? Give an example.

Part 1 of 3 | The Law of Conservation of Momentum

Conservation of momentum means that the total momentum before a collision or explosion equals the total momentum afterwards (when no external forces act). 1

This happens because the forces acting on each object during a collision are equal and opposite (Newton's Third Law). 2

The momentum lost by one object is gained by the other, so total momentum is conserved. 3

Equation: total momentum before = total momentum after. 4

Before



After



total momentum before = total momentum after

Fig 9.1 — A collision: object A strikes a stationary object B. Total momentum is the same before and after.

Questions

1. What is meant by "conservation of momentum"? (2 marks)
2. Why is momentum conserved in a collision? (Hint: think about Newton's Third Law.) (2 marks)
3. A white car (1 000 kg) travelling at 50 m/s collides with a green car (800 kg) at rest. After the collision the white car moves at 20 m/s (in the same direction).
 - (a) Calculate the change in momentum of the white car.
 - (b) How much momentum did the green car gain?
 - (c) Calculate the velocity of the green car after the collision.(5 marks)

Part 2 of 3 | Collision Calculations

For a collision where one object is initially at rest, work in two steps. 1

Step 1: find the change in momentum of the moving object = $(m \times u) - (m \times v)$. 2

Step 2: this momentum is transferred to the second object. Its velocity = momentum gained \div its mass. 3

Always keep the units consistent (kg, m/s, kg m/s). 4

Step 1: momentum gained

A 1 500 kg car travelling at 12 m/s hits a stationary 2 000 kg car. After the collision the first car moves at 4 m/s. Find the momentum gained by the second car.

V	$m = 1\,500\text{ kg}$ $u = 12\text{ m/s}$ $v = 4\text{ m/s}$
E	$p = m \times v$
S	before: $p = 1\,500 \times 12 = 18\,000$
S	after: $p = 1\,500 \times 4 = 6\,000$
S	gained = $18\,000 - 6\,000 = 12\,000$
U	kg m/s

Step 2: velocity of car 2

The second car (2 000 kg) gains 12 000 kg m/s. Find its velocity after the collision.

V	$p = 12\,000\text{ kg m/s}$ $m = 2\,000\text{ kg}$ $v = ?$
E	$p = m \times v$
S	$12\,000 = 2\,000 \times v$
S	$v = \frac{12\,000}{2\,000}$
S	$v = 6$
U	m/s

Questions

4. A 1 000 kg car travelling at 40 m/s collides with an 800 kg car at rest. After the collision the first car moves at 10 m/s.

- (a) Calculate the change in momentum of the first car.
 (b) Calculate the velocity of the second car after the collision.

(4 marks)

5. A 1 000 kg car travelling at 30 m/s collides with an 800 kg car at rest. After the collision the first car moves at 5 m/s.

- (a) Calculate the change in momentum of the first car.
 (b) Calculate the velocity of the second car after the collision.

(4 marks)

6. A car (1 200 kg) at 15 m/s crashes into a stationary van (2 400 kg). After the collision, the car moves at 3 m/s in the same direction.

- (a) Calculate the change in momentum of the car.
 (b) Calculate the velocity of the van after the collision.

(4 marks)

Part 3 of 3 | Explosions and Recoil

Conservation of momentum also applies to explosions (objects flying apart). 1

Before an explosion, total momentum = 0 (both objects at rest). 2

After the explosion, the two objects move in opposite directions with equal and opposite momenta, so the total is still zero. 3

Example: firing a rifle. The bullet moves forward; the rifle recoils backward. 4

A bullet (0.01 kg) fired from a rifle (2 kg) that recoils at 1 m/s: 5

momentum of rifle = $2 \times 1 = 2 \text{ kg m/s}$, so momentum of bullet = 2 kg m/s . 6

$v_{\text{bullet}} = p / m = 2 / 0.01 = 200 \text{ m/s}$. 7

Before



After



Fig 9.2 — Recoil: before firing the total momentum is zero; afterwards the gun and bullet carry equal and opposite momenta.

Questions

- 7.** Explain why a gun recoils when fired, using the idea of conservation of momentum. (2 marks)
- 8.** What is the momentum of a cannonball before the cannon is fired? Give a reason. (1 mark)
- 9.** A cannon fires a cannonball forwards at 250 m/s. The cannonball has a mass of 1 kg. Calculate the momentum of the cannonball after the cannon is fired. (2 marks)
- 10.** The cannon has a mass of 1 000 kg. Using conservation of momentum, calculate the recoil speed of the cannon. (4 marks)
- 11.** What is the momentum of a paintball before the gun is fired? Give a reason. (1 mark)
- 12.** A gun fires a paintball forwards at 90 m/s. The paintball has a mass of 0.003 kg. Calculate the momentum of the paintball after the gun is fired. (2 marks)
- 13.** The gun has a mass of 500 g. Using conservation of momentum, calculate the recoil speed of the gun. (4 marks)

EXAM QUESTION — Q9: Conservation of Momentum (6 marks)

Mark allocations shown as (n) following AQA convention.

Figure 9.3 shows a car of mass 1 000 kg moving at 20 m/s towards a stationary van of mass 2 000 kg. The car collides with the van. After the collision the car is at rest and the van moves forward.

Before

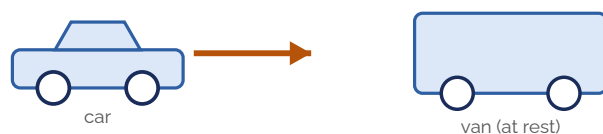

After



momentum is conserved in the collision

Fig 9.3 — A car collides with a stationary van (before and after).

(a) In a collision, the total momentum of the objects is usually conserved. What is meant by the term "momentum is conserved"?

(1)

(b) Calculate the change in the momentum of the car. Show clearly how you work out your answer and give the unit.

(3)

(c) Use the idea of conservation of momentum to calculate the velocity of the van after the collision. Show your working.

(2)

LESSON 10

Stopping Distance

Do Now

1. What is the equation for speed in terms of distance and time?
2. Name two forces that act on a moving car.
3. What effect does friction have on a moving vehicle?
4. State Newton's First Law of motion.

Part 1 of 3 | Thinking Distance

Thinking distance is the distance the vehicle travels while the driver reacts to a hazard – from seeing the hazard to pressing the brake – before the brakes are applied. 1

Reaction time is the time taken to react. For a healthy, alert driver it is typically 0.2–0.9 s. 2

Thinking distance is calculated from: thinking distance = speed × reaction time. 3

Thinking distance is therefore directly proportional to speed: double the speed and the thinking distance doubles. 4

Factors that increase the thinking distance by increasing the reaction time: tiredness, alcohol, drugs (including some medicines) and distractions (such as using a phone or loud music). 5

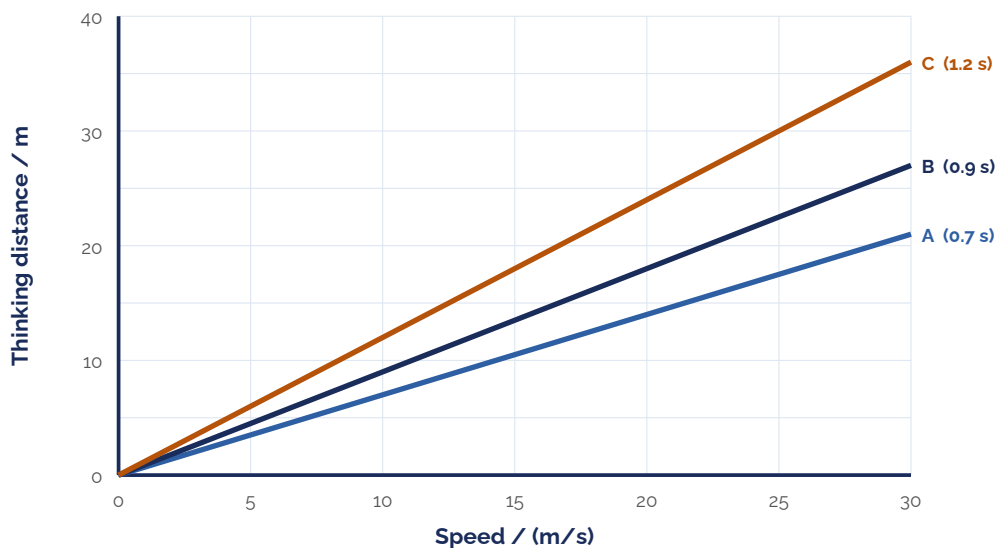

Fig 10.1 – Thinking distance against speed for three drivers with different reaction times.

Driver	Condition	Reaction time (s)
A	wide awake	0.7
B	using a hands-free phone	0.9
C	very tired and listening to music	1.2

Questions

1. (a) What is meant by the thinking distance?
(b) What is meant by a driver's reaction time? (2 marks)
2. Write the equation that links thinking distance, speed and reaction time. (1 mark)
3. Describe two factors that increase the thinking distance, and explain how each one does so. (2 marks)
4. Driver A (reaction time 0.7 s) is travelling at 22 m/s (about 50 mph). Calculate the thinking distance. (2 marks)
5. The table cannot be used to tell whether driver C's longer reaction time is caused by being tired or by listening to music. Explain why. (2 marks)
6. The three lines in Fig 10.1 show thinking distance against speed for drivers A, B and C. Match each line to the correct driver and explain how you decided. (2 marks)

Part 2 of 3 | Braking Distance

- Braking distance is the distance the vehicle travels from the moment the brakes are applied to the moment it stops. 1
- During braking, the kinetic energy of the vehicle is transferred to thermal (heat) energy in the brakes by the work done against friction – the brakes, tyres and road warm up. 2
- Braking distance is proportional to the speed squared (v^2); doubling the speed makes the braking distance about four times larger, so a braking-distance–speed graph is a curve. 3
- Factors that increase the braking distance: a higher speed; adverse weather conditions (rain, ice or snow); poor road conditions (a wet, icy or loose/greasy surface); and a vehicle in poor condition (worn brakes or worn tyres). 4
- Adverse weather and road conditions reduce the grip (friction) between the tyres and the road, so the vehicle travels further before stopping. A more heavily loaded (greater mass) vehicle also has a longer braking distance. 5

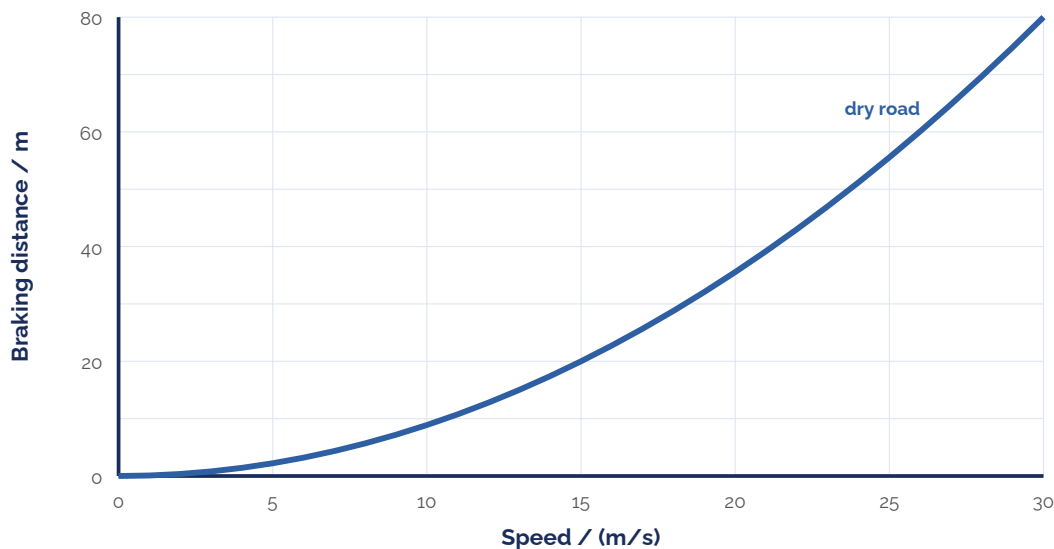

Fig 10.2 — Braking distance against speed: the curve rises ever more steeply because braking distance is proportional to v^2 .

Questions

- 7.** What is meant by the braking distance? (1 mark)
- 8.** Describe the energy transfer that takes place during the braking distance. (2 marks)
- 9.** Braking distance is affected by three kinds of factor. For each one, give an example:
 (a) the weather;
 (b) the road;
 (c) the condition of the vehicle. (3 marks)
- 10.** A car brakes from the same speed on three occasions: on a dry road, in heavy rain, and on ice. Explain, in terms of friction, why the braking distance is longest on ice. (2 marks)
- 11.** A graph of braking distance against speed is a curve, not a straight line. Explain why. (2 marks)
- 12.** On the same axes as a dry-road braking-distance curve, describe how the curve for an icy road would look. Explain your answer. (2 marks)
- 13.** Modern cars can often stop in a shorter distance. Explain what difference better brakes and better tyres make to the braking distance. (2 marks)

Part 3 of 3 | Stopping Distance

Stopping distance = thinking distance + braking distance. 1

It is the total distance travelled from the moment the driver sees a hazard to the moment the vehicle stops. 2

When the speed doubles, the thinking distance doubles (it is proportional to speed) but the braking distance increases about four-fold (it is proportional to v^2), so the stopping distance grows quickly with speed. 3

Adverse conditions increase the stopping distance: e.g. tiredness or alcohol increases the thinking distance, while rain or ice increases the braking distance. 4

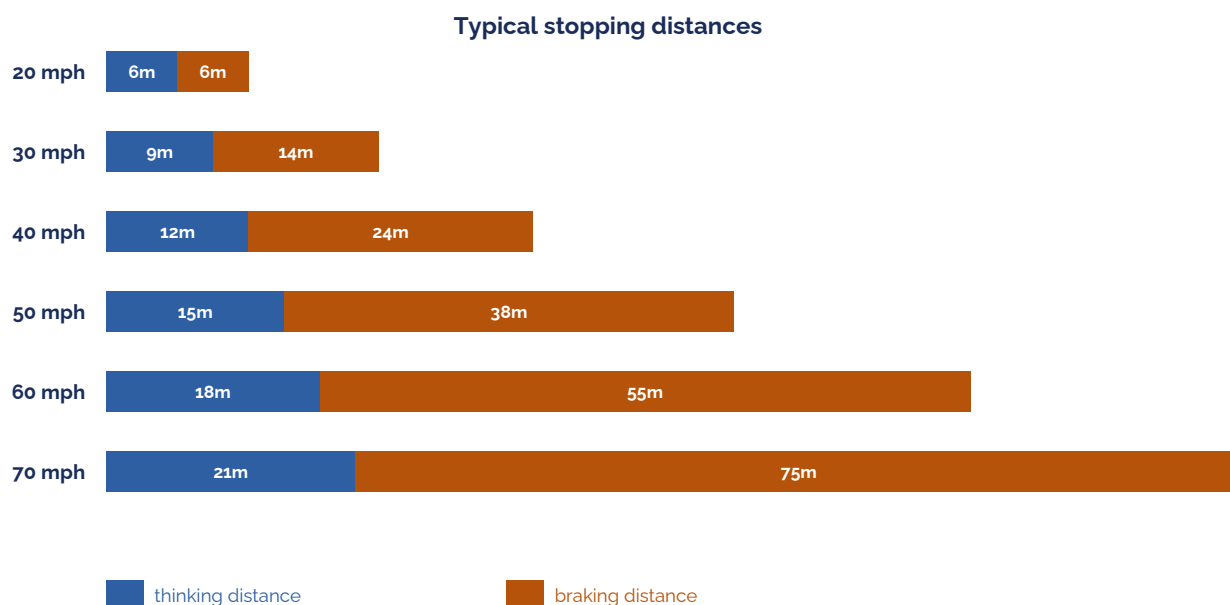

Fig 10.3 – Typical stopping distances at different speeds (thinking distance + braking distance).

Questions

- 14.** Write the equation for stopping distance. (1 mark)
- 15.** When the speed of a car doubles, compare how the thinking distance and the braking distance each change. (2 marks)
- 16.** At 40 mph the thinking distance is 12 m and the braking distance is 24 m.
(a) Calculate the stopping distance at 40 mph.
(b) Estimate the stopping distance at 80 mph. (3 marks)
- 17.** A tired driver is travelling in heavy rain. Explain how these conditions affect:
(a) the thinking distance;
(b) the braking distance;
(c) the overall stopping distance. (3 marks)

EXAM QUESTION — Q10: Stopping Distance (7 marks)

Mark allocations shown as (n) following AQA convention.

A driver of a car has to make an emergency stop. For this car, at one particular speed, the thinking distance is 9 m and the braking distance is 14 m. Figure 10.4 shows how the braking distance of the car changes with speed on a dry road.

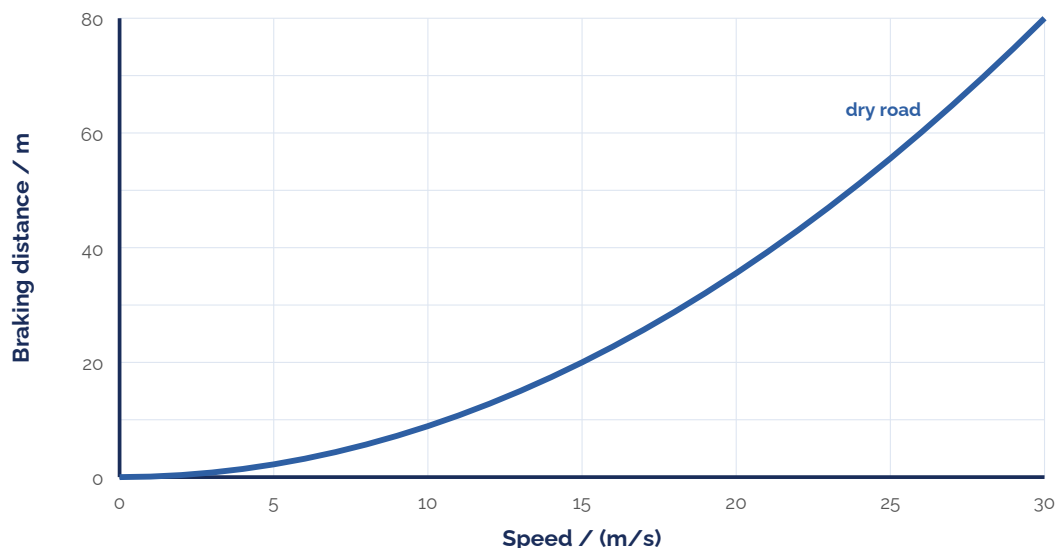

Fig 10.4 — Braking distance against speed for the car on a dry road.

- (a)** Calculate the total stopping distance of the car at this speed. (1)
- (b)** On Figure 10.4, sketch a line to show how the braking distance of the same car would change with speed on an icy road. (Describe your line.) (2)
- (c)** Which one of the following would also increase the braking distance of the car? Rain on the road / The driver having drunk alcohol / The driver having taken drugs. (1)
- (d)** Explain why increasing the speed of a car has a much larger effect on the braking distance than on the thinking distance. (3)

LESSON 11

Hooke's Law

Do Now

1. What is the equation for weight? State the units.
2. What does it mean for an object to be in equilibrium?
3. Give an example of an elastic material and an example of a plastic (inelastic) material.
4. If you hang a heavier mass on a spring, what do you think will happen to the extension? Explain.

Part 1 of 3 | Hooke's Law: $F = k \times e$

Hooke's Law: the extension of a spring is directly proportional to the force applied, provided the elastic limit is not exceeded. 1

This gives the equation: $F = k \times e$ 2

Where: F = applied force (in N), e = extension (in m), k = spring constant (in N/m). 3

The spring constant (k) measures how difficult it is to stretch a spring. A larger k means a stiffer spring. 4

A material that returns to its original shape when the forces are removed shows elastic behaviour (reversible). 5

A material that stays deformed when the forces are removed shows plastic behaviour (irreversible). 6

If too large a force is applied, the material exceeds its elastic limit and loses its elasticity. 7

Worked Example

A spring has a spring constant of 20 N/m. A force stretches it by an extension of 0.15 m. Calculate the force applied.

V	$k = 20 \text{ N/m}$ $e = 0.15 \text{ m}$ $F = ?$
E	$F = k \times e$
S	$F = 20 \times 0.15$
S	$F = 3$
U	N (Newtons)

Questions

1. (a) What is the equation that links force, spring constant and extension?
(b) What are the units of force, spring constant and extension?

(2 marks)

2. Calculate the force on a spring if:

- (a) $k = 10 \text{ N/m}$, $e = 0.20 \text{ m}$.
- (b) $k = 25 \text{ N/m}$, $e = 0.05 \text{ m}$.
- (c) $k = 150 \text{ N/m}$, $e = 0.15 \text{ m}$.

(2 marks)

3. If the spring constant is 30 N/m and a spring is stretched by 0.3 m, how much force has been applied?

(2 marks)

4. If the spring constant is 12.6 N/m and a spring is stretched by 0.25 m, how much force has been applied?

(2 marks)

5. What force would be needed to extend a spring with $k = 10 \text{ N/m}$ by an extension of 0.3 m?

(2 marks)

6. Explain the difference between elastic behaviour and plastic behaviour.

(2 marks)

Part 2 of 3 | Stiff and Soft Springs

A force–extension graph for a spring that obeys Hooke's Law is a straight line through the origin – force and extension are directly proportional. 1

The spring constant (k) tells you how stiff a spring is. A stiff spring has a large spring constant; a soft spring has a small spring constant. 2

With force on the y-axis and extension on the x-axis, the gradient of the line is the spring constant k . 3

A steeper line therefore means a larger spring constant (a stiffer spring); a less steep line means a smaller spring constant (a softer spring). 4

For the same force, the spring with the larger spring constant extends less. Use $F = k \times e$ to compare the forces needed for a given extension. 5

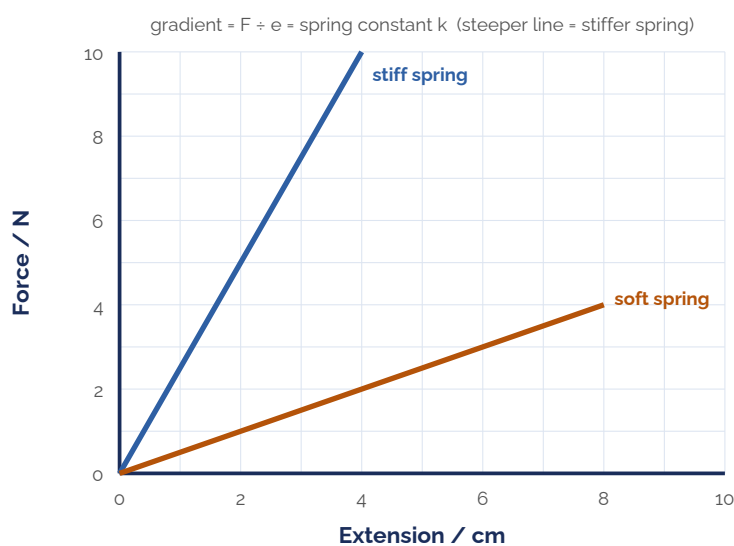

Equation of a straight line:

$$y = mx + c$$

$$F = ke$$

Therefore

$$m = k \text{ and } c = 0$$

Fig 11.1 – Force–extension graph: with force on the y-axis and extension on the x-axis, the gradient of each line equals that spring's constant k .

Stiff spring

The stiff spring in Fig 11.1 has a spring constant of 50 N/m. A force stretches it by an extension of 0.10 m. Calculate the force applied.

V	$k = 50 \text{ N/m}$ $e = 0.10 \text{ m}$ $F = ?$
E	$F = k \times e$
S	$F = 50 \times 0.10$
S	$F = 5$
U	N (Newtons)

Soft spring

The soft spring in Fig 11.1 has a spring constant of 20 N/m. A force stretches it by the same extension of 0.10 m. Calculate the force applied.

V	$k = 20 \text{ N/m}$ $e = 0.10 \text{ m}$ $F = ?$
E	$F = k \times e$
S	$F = 20 \times 0.10$
S	$F = 2$
U	N (Newtons)

Questions

7. Look at the two springs in Fig 11.1.

- (a) Which line shows the spring with the larger spring constant?
 (b) Explain how the graph shows which spring is stiffer.

(2 marks)

8. Explain why, for the same applied force, the stiff spring extends less than the soft spring.

(2 marks)

9. For an extension of 0.3 m, calculate the force needed to stretch:

- (a) the stiff spring ($k = 50 \text{ N/m}$);
 (b) the soft spring ($k = 20 \text{ N/m}$).
 (c) Which spring needs the larger force?

(3 marks)

Part 3 of 3 | Finding k and e, and Problems with Mass

You can also find a missing spring constant or extension by calculation. Always start from $F = k \times e$, substitute in the values you know, and then rearrange to make the unknown the subject. 1

Unit conversions: $1 \text{ g} = 0.001 \text{ kg}$; $1 \text{ cm} = 0.01 \text{ m}$; $1 \text{ mm} = 0.001 \text{ m}$. 2

The extension is the increase in length: $\text{extension} = \text{stretched length} - \text{original length}$. 3

If you are given a mass, first find the force using $F = W = m \times g$, then use $F = k \times e$. 4

Example (finding k)

A force of 6 N stretches a spring by an extension of 0.2 m. Calculate the spring constant.

V	$F = 6 \text{ N}$ $e = 0.2 \text{ m}$ $k = ?$
E	$F = k \times e$
S	$6 = k \times 0.2$
S	$k = \frac{6}{0.2}$
S	$k = 30$
U	N/m

Example (finding e)

A force of 4.5 N is applied to a spring with a spring constant of 9 N/m. Calculate the extension.

V	$F = 4.5 \text{ N}$ $k = 9 \text{ N/m}$ $e = ?$
E	$F = k \times e$
S	$4.5 = 9 \times e$
S	$e = \frac{4.5}{9}$
S	$e = 0.5$
U	m (metres)

Questions

11. Calculate the spring constant if:

- (a) $F = 150 \text{ N}$, $e = 0.075 \text{ m}$.
 (b) $F = 50 \text{ N}$, $e = 0.1 \text{ m}$.

(2 marks)

12. Calculate the extension if:

- (a) $F = 15 \text{ N}$, $k = 150 \text{ N/m}$.
 (b) $F = 45 \text{ N}$, $k = 90 \text{ N/m}$.

(2 marks)

13. A 6 N weight is hung on a spring and it extends by 0.2 m. What is the spring constant?

(2 marks)

14. A force of 12 N is applied to a spring with a spring constant of 40 N/m. How much will the spring extend by?

(2 marks)

15. A mass of 620 g is hung on a spring of spring constant 31 N/m. ($g = 10 \text{ N/kg}$)

- (a) Convert 620 g into kg.
 (b) Using $F = m \times g$, find the force of the mass acting on the spring.
 (c) Calculate the extension of the spring.

(3 marks)

16. A spring with $k = 40 \text{ N/m}$ starts at a length of 13 cm and extends to 21 cm.

- (a) What is the extension in cm?
 (b) Convert the extension to metres.
 (c) What is the force on the spring?

(3 marks)

17. A 200 g mass hangs on a spring with $k = 40 \text{ N/m}$. ($g = 10 \text{ N/kg}$) Calculate the extension.

(2 marks)

18. A 500 g mass hangs on a spring, stretching it from 5 cm to 15 cm. Calculate the spring constant. ($g = 10 \text{ N/kg}$)

(2 marks)

19. A 750 g mass hangs on a spring, stretching it from 2.5 cm to 10 cm. Calculate the spring constant. ($g = 10 \text{ N/kg}$)

(2 marks)

20. Stretch: write some of your own questions and solve them. To make them harder, put the extension in cm or mm, or give a mass in grams. Try to make the numbers realistic.

(0 marks)

EXAM QUESTION — Q11: Hooke's Law (7 marks)

Mark allocations shown as (n) following AQA convention.

A child launches a toy glider into the air using a stretched rubber band. Figure 11.2 shows the glider in flight, with two forces acting on it.

A toy glider in flight

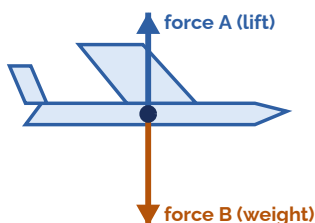

Fig 11.2 — A toy glider in flight: force A acts upwards and force B acts downwards.

- (a)** Before launch, the rubber band is stretched by 0.12 m. The rubber band behaves like a spring with a spring constant of 25 N/m. Calculate the force stored in the rubber band. (2)
- (b)** As the glider is launched, the _____ energy stored in the stretched rubber band decreases and the glider gains _____ energy. Choose the two correct words from: chemical, elastic potential, kinetic, thermal. (2)
- (c)** Force B is the downward force on the glider. What name is given to force B? (Choose: drag / friction / weight) (1)
- (d)** When force B is greater than force A, what happens to the downward speed of the glider? Choose one and explain: increases / stays constant / decreases. (2)

LESSON 12

Hooke's Law Practical

Do Now

1. State Hooke's Law.
2. Write the equation $F = k \times e$. Rearrange it to find k and e .
3. What is the difference between elastic and plastic deformation?
4. What would a graph of Force vs Extension look like for a spring obeying Hooke's Law? Describe its shape.

Part 1 of 3 | Aim, Apparatus and Method

Aim: to investigate the relationship between the force applied and the extension of a spring. 1

Apparatus: a spring, clamp stand and clamps, ruler, 100 g masses and a mass hanger. 2

Method: 3

1. Hang the spring from the clamp. Add a pointer so the end is easier to read against the ruler. 4

2. Measure the unstretched length of the spring (at a force of 0 N). 5

3. Hang the 100 g mass hanger on the spring (this applies a force of about 1.0 N). 6

4. Measure the new length of the spring. 7

5. Add further masses, measuring and recording the length each time. Take at least 8 readings. 8

6. Calculate the extension each time: extension = current length – unstretched length. 9

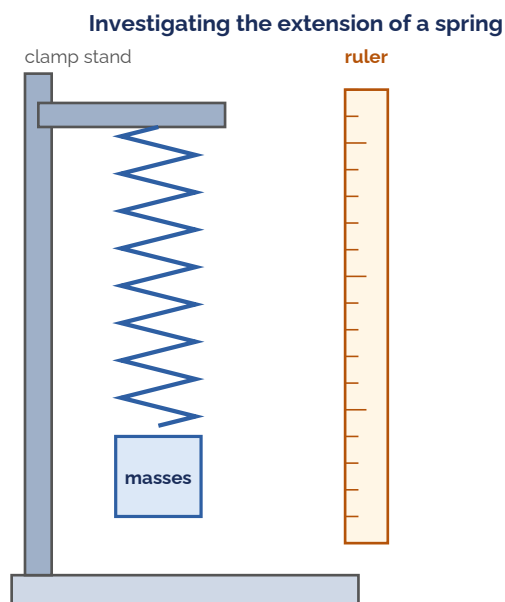

Fig 12.1 – Apparatus for the Hooke's Law investigation: spring on a clamp stand with a ruler and masses.

Questions

Mass (kg)	Force (N)	Length (cm)	Extension (cm)

- What is the aim of this investigation? (1 mark)
- List the apparatus needed for this investigation. (2 marks)
- Explain how you would calculate the extension of the spring from your measurements. (1 mark)
- Why is it important to take at least 8 readings in this experiment? (1 mark)

Part 2 of 3 | Plotting the Graph

- | | |
|---|---|
| Plot a graph of extension (cm) on the y-axis against force (N) on the x-axis. | 1 |
| Draw a single straight line of best fit through the points. | 2 |
| A straight line through the origin confirms Hooke's Law (direct proportionality between force and extension). | 3 |
| If the line begins to curve at higher forces, the spring has passed its elastic limit. | 4 |

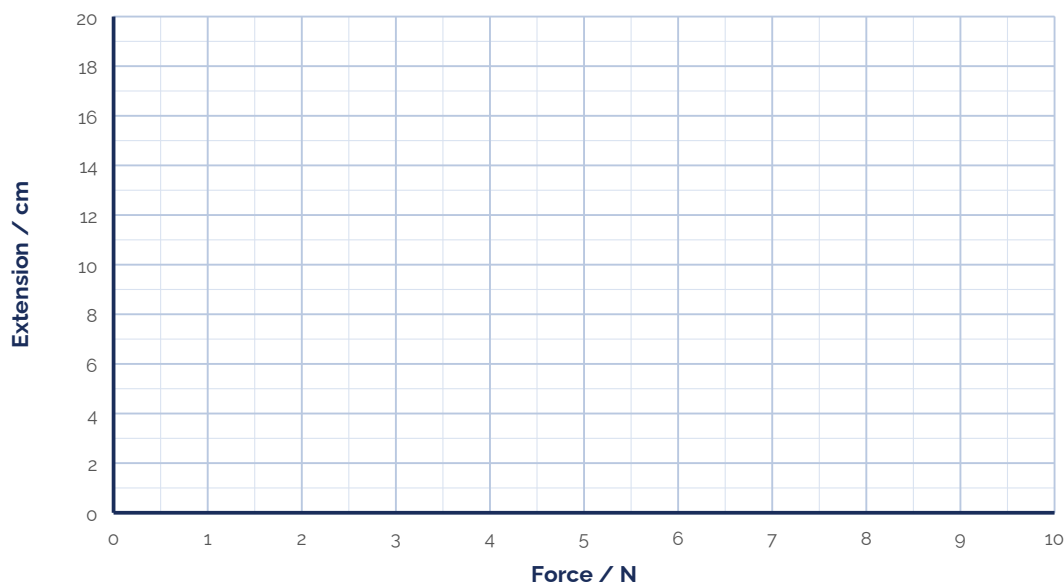

Fig 12.2 – Grid for plotting extension (cm) against force (N).

Questions

- Plot a graph of extension (cm) on the y-axis against force (N) on the x-axis using your results table from Part 1. Draw a line of best fit. (2 marks)
- Describe the shape of your graph, and explain what it tells you about how the spring behaves. (2 marks)

Part 3 of 3 | Finding the Spring Constant

The spring constant can be found from the graph using $k = \text{force} \div \text{extension}$ (in SI units, N/m).	1
Choose two points that are far apart on the line of best fit to read off a force and the matching extension.	2
Convert the extension from cm to m before calculating (divide by 100).	3
A stiffer spring (larger k) gives a less steep extension–force line; a softer spring (smaller k) gives a steeper line.	4

Questions

7. Use your line of best fit to calculate the spring constant k of your spring. State the units. *(2 marks)*
8. Suggest why the student measured the extension for several different forces rather than just one. *(1 mark)*

EXAM QUESTION — Q12: Hooke's Law Practical (9 marks)

Mark allocations shown as (n) following AQA convention.

A student hangs masses on a spring and measures the extension for several different forces. Figure 12.3 shows the student's results plotted on a grid, with the points for 5 N and 6 N still to be added.

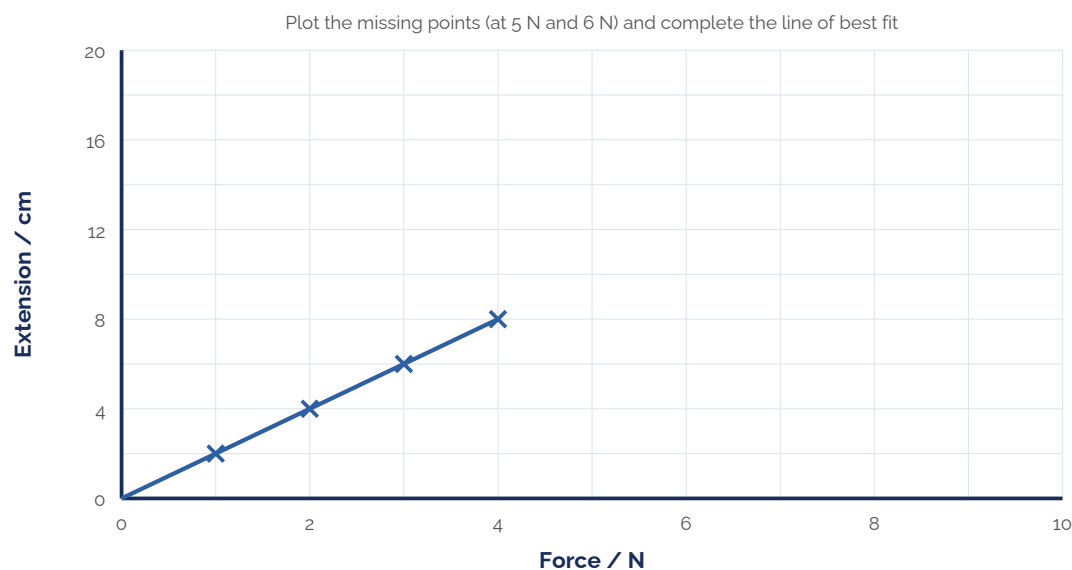

Fig 12.3 – The student's extension–force results (two points still to be plotted).

- (a) The student measured the extension for several different forces rather than just one. Suggest why. (1)
- (b) The extension is 10 cm at 5 N and 12 cm at 6 N. On Figure 12.3, plot these two points and complete the line of best fit. (Describe where the points go.) (2)
- (c) Write down the equation that links extension, force and spring constant. (1)
- (d) Use the graph to calculate the spring constant of the spring. Give your answer in newtons per metre. (4)
- (e) A student wants to use this spring as a forcemeter to find the weight of an unknown object. Explain how they could use the spring and their graph to do this. (1)